

ARCHIVED

APPROVED CODE OF PRACTICE FOR THE USE OF

VISUAL DISPLAY UNITS

IN THE PLACE OF WORK

ARCHIVED

Published by the Occupational Safety and Health Service,
Department of Labour, Wellington, New Zealand.

First edition 1984

Revised 1988

Revised 1993 and published as an approved code of practice

New edition October 1995

Reprinted February 1996

ISBN 0-477-03575-2

OSH 3211 AFC

\$20 (incl. GST) as a package, \$10 this booklet only





ARCHIVED

FOREWORD

I have approved this statement of preferred work practices, which is an *Approved Code of Practice for the Use of Visual Display Units in the Place of Work*, under section 20 of the Health and Safety in Employment Act 1992.

When a code is approved, a court may have regard to it in relation to compliance with the relevant sections of the Act. This means that if an employer in an industry, or using a process to which an approved code applies can show compliance with that code in all matters it covers, a court may consider this to be compliance with the provisions of the Act to which the code relates.



Hon. Doug Kidd
Minister of Labour
September 1995

ARCHIVED

NOTICE OF ISSUE

I have issued this *Approved Code of Practice for the Use of Visual Display Units in the Place of Work*, being a statement of preferred work practices or arrangements for the purpose of ensuring the health and safety of persons to which this code applies and persons who may be affected by the activities covered by this code.



J. M. Chetwin
Secretary of Labour
September 1995



ABOUT THIS CODE

This approved code of practice is in four parts. These are supported by three appendices and three supporting publications.

Part 1 introduces the code and explains its status and how it should be used.

Part 2 contains recommendations about the design of VDU work under five main headings:

The organisation of VDU work.

The design of the computer components.

The design of the office furniture.

The design of the office environment.

Information and training.

Part 3 discusses several potential health problems that can arise from VDU use, and makes recommendations about how employers should monitor for these problems.

Part 4 explains the relationship between the code and the Health and Safety in Employment Act 1992.

Appendix A shows where more information about the health and safety of VDU work can be found.

Appendix B summarises the contents of ISO 9241: *Ergonomic requirements for office work with visual display terminals*.

Appendix C is a list of the addresses of the branch offices of the Occupational Safety and Health Service of the Department of Labour. Staff at these offices are able to assist with the application of this code of practice.

ADDITIONAL PUBLICATIONS

Three additional publications support this code:

Checklists for the Use of Visual Display Units in the Place of Work has been prepared to help employers work through the recommendations in part 2 of the code. The checklists are:

1. Monitoring hazards of VDU work: Work organisation.
2. Visual display unit selection.
3. Identifying hazards of VDU workstation design.
4. Evaluation of workplace visual conditions.

How to Use Your VDU Safely is a brief guide for users that promotes workstation comfort and provides general advice on the work environment where VDUs are used.

An accompanying poster summarises the information in the brief guide.

1. INTRODUCTION

- 1.1 What is a VDU? 10
- 1.2 What is this approved code of practice? 10
- 1.3 Why is a code of practice for VDU needed? 10
- 1.4 Who should use this code? 11
- 1.5 How should employers use this code? 11

2. WHAT YOU SHOULD DO TO COMPLY WITH THIS CODE

- 2.1 The benefits of designing VDU work carefully 14
- 2.2 Planning for VDU work 14
- 2.3 Organising VDU work 16
- 2.4 Computer hardware and software 18
- 2.5 Office furniture 23
- 2.6 The office environment 32
- 2.7 Arranging the hardware and furniture 39
- 2.8 Hazard notification and training 41

3. HEALTH PROBLEMS OF VDU WORK

- 3.1 Health problems 43
- 3.2 Health monitoring 48

4. HOW THIS CODE RELATES TO THE HEALTH AND SAFETY IN EMPLOYMENT ACT

- 4.1 Introduction 54
- 4.2 Application of this code 55
- 4.3 Giving information about hazards to employees and training for employees 55
- 4.4 Accident reporting and recording 56
- 4.5 Work in private homes 56



Glossary 57
References 59

APPENDICES

Appendix A: Further reading 61
Appendix B: ISO 9241 *Ergonomic requirements for office work with visual display terminals* 63

Index 65





PART 1

INTRODUCTION

THIS PART CONTAINS

- 1.1 *What is a VDU?* 10
- 1.2 *What is this approved code of practice?* 10
- 1.3 *Why is a code of practice for VDUs needed?* 10
- 1.4 *Who should use this code?* 11
- 1.5 *How should employers use this code?* 11

This part defines a visual display unit, describes the status of this code in relation to the Health and Safety in Employment Act, and explains how employers and employees should use the code.

1.1 WHAT IS A VDU?

For the purposes of this code a visual display unit (VDU) is defined as a combination of an electronic display screen, a keyboard and/or an input device. This is the definition used by the International Standards Office in ISO 9241: *Ergonomic requirements for office work with visual display terminals* (International Standards Office, Geneva, 1992).

ISO 9241 is in 18 parts — some of which have been published, while others are still being developed. Appendix B comprises a list of these parts, with the status of each.

Using a VDU includes such activities as entering text and data, monitoring data displayed on the screen, or building computer programmes and applications.

1.2 WHAT IS THIS APPROVED CODE OF PRACTICE?

This code has been approved by the Minister of Labour. It is a guide for employers and employees on how to organise VDU work to maximise efficiency, safety and health.

It is a statement of preferred practice — defining minimum requirements and promoting excellence in health and safety. It replaces both the 1988 publication and the interim approved code of 1993.

It explains how the Health and Safety in Employment Act applies to work with VDUs and contains guidance on how to meet the requirements of the Act by eliminating, isolating or minimising any hazards associated with VDU use.

It identifies practices that are known to pose risks to VDU users, and also those practices that promote good health and the wellbeing of VDU users.

It provides guidelines on such aspects as cost-effectiveness, legal requirements, and equipment standards.

The code encourages a co-operative approach between users and managers to achieve the most effective use of VDUs in the workplace.

1.3 WHY IS A CODE OF PRACTICE FOR VDU NEEDED?

Employers have obligations to provide for the health and safety of employees under the Health and Safety in Employment Act. As well, in proceedings for an offence against the Act, a court may take into account whether or not an employer has followed the requirements of a code of practice.

The introduction of VDUs in the workplace has changed the nature of employment, the structure of jobs, work surroundings, and organisations themselves. While, in many cases, this has led to increased skills and efficiencies, it has sometimes led to health problems. Often these are due to the inefficient use of equipment and labour, and misunderstandings on the part of both employers and employees.

The rapid transition to the electronic workstation has also produced its own myths, often encouraged by a lack of knowledge or understanding. This code aims to improve this situation and to dispel many of the myths surrounding VDU use.



1.4 WHO SHOULD USE THIS CODE?

The recommendations in this code are aimed mostly at employers.

A supplementary booklet, aimed more at employees: *How to Use Your VDU Safely*, accompanies this code. It focuses on many of the recommendations in the code and will help employees get the best out of their workstations.

Although this code was developed primarily from the experience of VDU users in offices, its recommendations will often be applicable to other types of workplace. We strongly encourage the adoption of the recommendations in private homes, for example.

1.5 HOW SHOULD EMPLOYERS USE THIS CODE?

APPLICATION

Employers and employees should use this code in any situation in the workplace where a person uses a VDU during their normal work.

When deciding if the code applies in a particular situation, you should consider factors such as the nature and duration of the task, the type of equipment being used, and aspects of the physical environment.

As an employer you should treat each situation on its merits and take account of the differences between individuals and the variety of tasks they perform.

The code acknowledges that, while there are some problems known to cause difficulties for some VDU users, many workplaces and many users will be free of these problems.

The code therefore recommends preferred practices, rather than making rigid requirements — allowing greater flexibility.

FLEXIBILITY IS IMPORTANT

You may choose to meet only some of the recommendations given in this code, using other means to satisfy the requirements of the Health and Safety in Employment Act. In this case, you must also accept the obligation to provide an equivalent standard of health and safety.

The code allows this flexibility because it may be difficult or inappropriate for you to meet a specific requirement in a particular circumstance. (In this way the code differs from a regulation, where you must meet each specific requirement.)

Parts of the code may become inappropriate or obsolete as technology advances and as changes occur in VDU hardware, software and work patterns. In this case you will still have an obligation under the Health and Safety in Employment Act, but you will have to devise alternative measures to deal with the new problems, and you will need to show that an equivalent or better level of health and safety is achieved by these measures.

Wherever there is *developing knowledge*, you must make a reasonable effort to keep up with it. Where you encounter new information relevant to health and safety, you must apply it within a reasonable time.

ARCHIVED

Because of these possibilities, the code has been written so that changes in technology and work practices can be accommodated, as far as possible, without the need for frequent revisions.

If you meet the requirements in part 2 of this code, you would most likely meet your obligations under the HSE Act.





PART 2 WHAT YOU SHOULD DO TO COMPLY WITH THIS CODE

THIS PART CONTAINS

- 2.1 The benefits of designing VDU work carefully 14*
- 2.2 Planning VDU work 14*
- 2.3 Organising VDU work 16*
- 2.4 Computer hardware and software 18*
- 2.5 Office furniture 23*
- 2.6 The office environment 32*
- 2.7 Arranging the workstation and VDU equipment 39*
- 2.8 Hazard notification and training 41*

This part of the code makes recommendations about planning and organising VDU work, selecting and arranging computer components and office furniture, and the physical aspects of the office environment. A brief section at the end describes how employees should be advised of the hazards they may face from VDU work, and the contents of training programmes.

If you meet the requirements in this part of the code, you would most likely meet your obligations under the Health and Safety in Employment Act.

2.1 THE BENEFITS OF DESIGNING VDU WORK CAREFULLY

VDU work involves a complex interaction between VDU users, other people, computer equipment, furniture, workstation equipment and the physical aspects of the office environment.

Figure 1
Interactions between the person, the VDU hardware, the workstation, the environment and the way work is organised all need to be considered if health and safety are to be maximised.

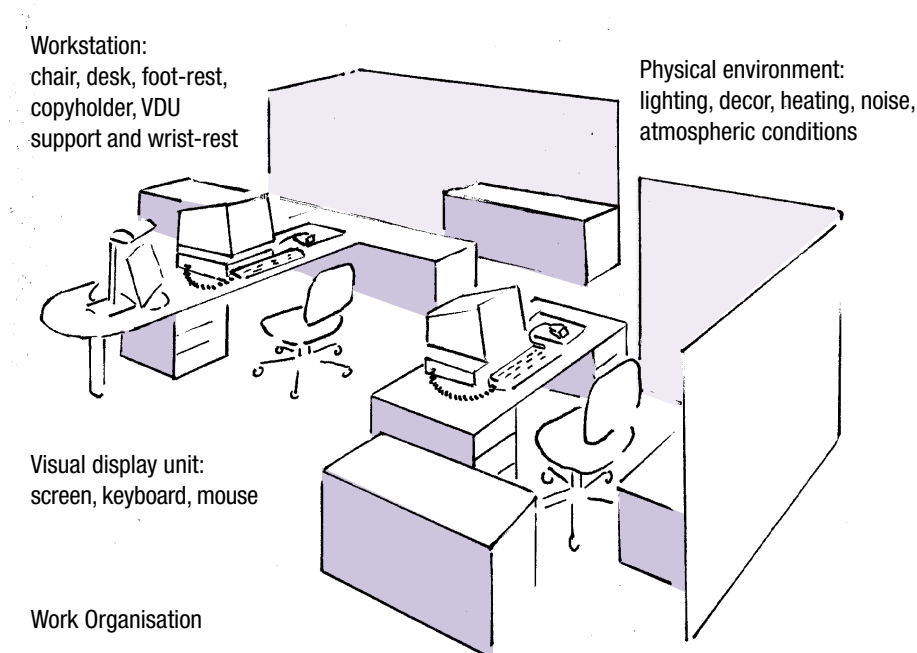

People vary immensely. This means that jobs, the working environment and the organisation of work need to be flexible so that each VDU user can be catered for. People will always be required to adjust, to some extent, to suit conditions at their work. But if you use good design at VDU workplaces, you will ease that adjustment. When you do this it is likely that workers will have:

- Fewer injuries;
- Less absenteeism;
- Increased efficiency;
- Reduced errors; and
- Increased job satisfaction.

2.2 PLANNING FOR VDU WORK

Every business plan has health and safety implications. When you are preparing a business plan that makes substantial changes or additions to work

performed by VDU users, you should consider health and safety at the outset.

Topics that you should consider include:

- Business outcomes to be satisfied;
- Planning for and with the user;
- Facilities planning;
- Information technology equipment planning; and
- Health and safety.

BUSINESS OUTCOMES

Every decision to purchase new VDUs, or to alter the work done by users of existing ones, is a result of business planning (which may be formal or informal). Use the planning process to define the policies and responsibilities which will apply in the VDU environment. Your business plan should also identify the tasks to be done by workers, workflows and the inter-relationships between the various people performing the work.

PLANNING FOR AND WITH THE USER

Plan for the needs of VDU users, as well as planning for the work they are to do. Include both in your business plans. Some of the things you should consider in a total office environment are described under the following three headings.

FACILITIES PLANNING

Plan the allocation of work space for operators and others in a VDU setting so that the tasks, the equipment used, storage needs and environmental factors are all considered.

Place wiring — trunk cabling and switchboards — so as to minimise worker exposure to electric and magnetic fields.

Locate VDU operators and others in relation to physical factors such as access-ways, cabling and other reticulation systems, VDU monitors, storage and workstation layout, so that they have enough room to move freely, can open drawers safely and are free from tripping hazards.

Take account of the effect of equipment on others. Consider the location of photocopiers, printers and computer fan outlets, swivelling monitor arms, and shared monitors.

Make sure that your design procedures will allow for changes in work areas in the future, as inevitable reorganisation occurs.

Seek a balance between the costs of accommodation, fitout or refurbishment and the potential savings you can make from intelligent planning for the users' needs. It may be short-sighted to allow costs to be the principal factor in assessing the suitability of a work environment.

INFORMATION TECHNOLOGY EQUIPMENT PLANNING

Consult users when defining the technical solutions to the business problem. VDU operators work in a system that comprises software, paper forms, other people, procedures and computer and workstation equipment. These components, together with the physical aspects of the environment, interact. Selecting equipment for a system is therefore a delicate process of balance and compromise.

HEALTH AND SAFETY

Unless you involve users of the system in the planning process, you will find it hard to make necessary decisions, including those affecting health and safety. Education and training for all involved with the system will stem from this consultation.

2.3 ORGANISING VDU WORK

As well as the workstation's components and the physical aspects of the environment, the way you organise work can affect the health of VDU users. The pace of work and the variety and nature of tasks can change when new technology is introduced. These changes can be dramatic. They can also take time to occur, as people begin to exploit the possibilities of the new technology.

Do not assume that introducing new technology will cause an immediate reduction in the number of staff you need to accomplish tasks. Make a careful judgement about the numbers of staff you require and the nature of the tasks you want them to do.

The way supervisors supervise has a bearing. Although difficult or impossible to measure, the adverse effect of certain supervision styles is frequently described as a source of tension at work.

Maximise health, safety and efficiency by incorporating the recommendations that follow when you design VDU tasks. Tension and stress have been identified as important risk factors for physical discomfort at work (see part 3), and many of these recommendations are designed to avoid these potential sources of health problems.

The provisions that follow are reproduced as checklist 1 in the accompanying publication.

TASK SPECIFICATION

1. Provide clear job descriptions and performance specifications.

Clear job descriptions and performance specifications remove uncertainty, clarify goals and aid the understanding of tasks. These can have the effect of reducing tension.

2. Consider the nature of the tasks and the job.

Monotonous tasks, tasks where specialisation is too great, and tasks where the variation is low or where the operator has no control over work flows are all



regarded as factors potentially counterproductive to health. Where monotonous or boring tasks exist, you should consider implementing job rotation. Whether the job is interesting to the person is also a factor. When tasks change, you will need to re-assess the job for potential problems.

SUPERVISION PRACTICES

3. Create clear and unambiguous lines of reporting.

Make sure that each operator has only one supervisor, where possible.

If a person has more than one supervisor, create a system that avoids pressure on the person from potential deadline or other conflicts.

These are recognised techniques to reduce tension. A person with two supervisors may have conflicting deadlines imposed on them, and should not have to make the decision as to which one to meet.

WORKLOADS

4. Schedule work to avoid recurrent deadline stress.

When normal work has been planned to avoid constant, recurring deadlines, people are able and willing to work harder when deadlines become urgent. Monthly accounting returns are an example.

5. Anticipate peak workloads.

In slacker periods, prepare work for those times when deadlines become urgent.

6. Discuss workloads with staff.

Bonus systems of payment and excessive overtime are two areas of concern, because both tend to increase the amount of work that operators may have to do. These practices can lead to an increased risk of health problems. Discussing and agreeing on workloads with staff will help you reduce these effects.

7. Assess the situation when staff are absent.

When staff are absent sick or on leave, an extra load may be placed on the remaining staff. This may be a material cause of increased discomfort.

8. Build up to speed gradually when starting a job or after an absence.

When a person is new to a job or when returning to work after an absence (holiday or sick leave), a gradual build-up to normal speed is recommended.

WORK MONITORING

9. Discuss work monitoring practices with staff.

Work monitoring, including electronic monitoring, is often a part of business practice. Most people like to know how well they are performing, but it ought to be remembered that people vary in their ability to carry out tasks. When staff perceive work monitoring as a means towards discipline, they may react adversely to it. If you communicate openly and clearly about work monitoring practices, you will reduce tension that may result from the practice.

Work quotas, and the implied monitoring practices, should include allowance for breaks, micropauses and exercises, as mentioned below.

BREAKS

10. Provide opportunities for breaks.

Breaks away from VDU work should be provided to prevent the build-up of fatigue. To be effective, breaks should be short and frequent, and should take place before fatigue occurs.

Where work is screen-intensive, or when the VDU task requires a high degree of concentration, a 10-minute break every hour may be appropriate. For prevention of physical discomfort — muscle aches and pains — micropauses (see below) are preferred.

When an operator takes a break of several minutes, she or he should take a complete break from the VDU work. This may involve doing exercises or other tasks, and should ideally, incorporate the opportunity to move around.

11. Provide for micropauses.

Micropauses are brief pauses for muscle relaxation, built in to the rhythm of the work — a brief pause of 5-10 seconds every 3 minutes. Micropauses are of most value when relaxation is complete, so operators should have training in relaxation. Micropauses take little time out of the working day and add to overall productivity.

STAFF NUMBERS

12. Have enough people to do the job.

This may be an important factor when companies “downsize”.

PREGNANCY

13. Consider pregnant operators.

The comfort of pregnant VDU operators should be carefully considered. A transfer to other duties should be considered if the operator wishes to do so and if other duties are available.

2.4 COMPUTER HARDWARE AND SOFTWARE

This section lists recommendations for the three common items that are part of VDU work — the VDU monitor, the keyboard and the mouse. Alternative devices that provide input to the computer, such as trackballs and the digitiser tablet, and puck are also mentioned briefly.

COMPLIANCE WITH STANDARDS

If your VDU monitor, keyboard and mouse meet the requirements of the appropriate parts of ISO 9241, or a similar standard that provides an equivalent or greater standard of protection for health¹, it will fulfil the requirements of the Health and Safety in Employment Act with regard to the design of this equipment. (ISO 9241 consists of 18 parts. Some are complete, while others are still in development. Appendix B shows the status of the different parts.)

Equipment certified to any standard such as ISO 9241 is tested over a short



period on a particular date. Compliance at the time of testing may not mean compliance over the lifetime of the equipment. The objective of this code is that VDU equipment will meet a sufficient standard at all times. This means that equipment should be maintained as required.

Compliance with the recommendations in one of the standards mentioned above is the preferred means of establishing that VDU equipment is of an acceptable design. It is recognised that there is equipment which may not have been tested and certified to indicate compliance with one of these standards. You can still use this equipment, as long as it meets the provisions that follow. Some of these provisions are of a practical or operational nature, and are difficult to measure.

If you suspect that non-compliance with any of the provisions that follow is the source of a health problem, then, when you have eliminated all other possible causes of the problem, get the equipment checked by an accredited laboratory against the relevant provision(s) of ISO 9241 or similar.

The provisions that follow are reproduced in checklist 2 in the accompanying publication. This checklist may be used when purchasing VDU monitors and keyboards.

Figure 2
VDU hardware: monitor, keyboard and mouse.

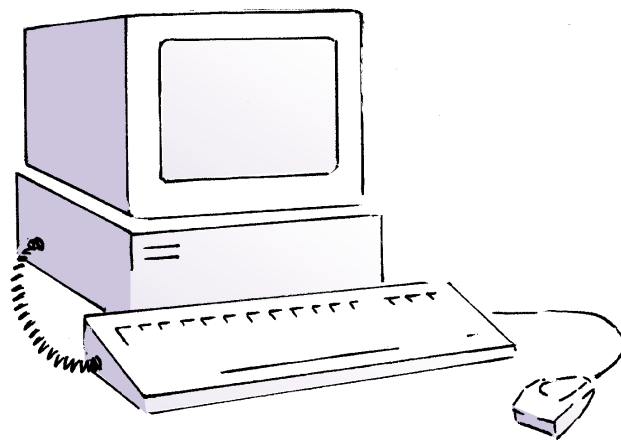

VDU MONITOR

Recommendations for the monitor are listed under three headings:

- Visual aspects;
- Physical adjustability of the VDU monitor; and
- Electric and magnetic fields.

Visual aspects

The screen image should be legible to the person using the equipment, as follows:

1. The brightness and contrast of the display should be adjustable.
2. Screen images should be sharp and clear.

3. The display should have no perceptible jitter, swim or flicker. *Screen legibility is affected by other factors as well. See also points discussed about lighting under office furniture and office environment.*
4. Characters displayed on the screen should be easily legible.
5. The monitor should have implosion protection. (A standard provision on all modern monitors.)
6. There should be provision to clean the screen.
7. Be aware that some screen colour combinations are better than others.

Physical adjustability of the VDU monitor

To ensure postural and visual comfort, the position of the VDU monitor should swivel and be adjustable for height, for eye-screen distance and for tilt.

Figure 3
Recommended minimum adjustability of the VDU monitor — side elevation.

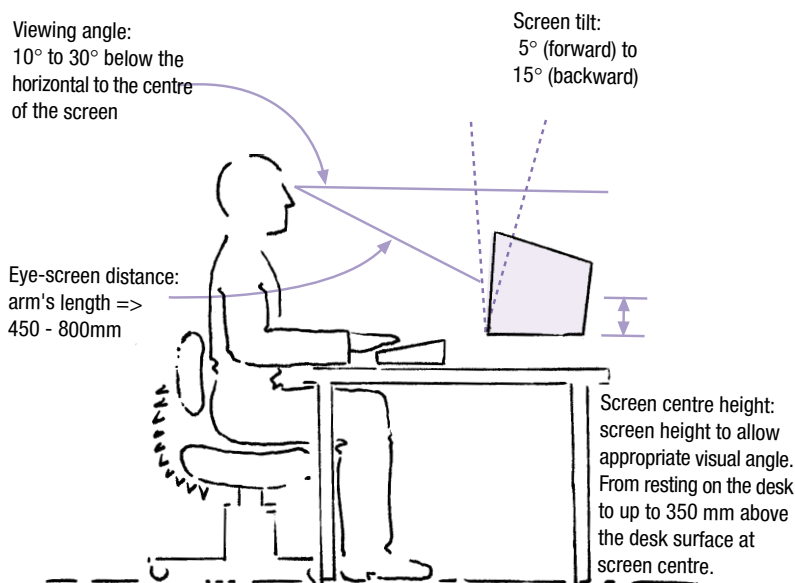

If several people use a VDU workstation, the degree of adjustment required will be greater than for a single user. In the case of several operators, the use of an adjustable VDU support is recommended (see figure 3).

Note that both monitor height and tilt need to be adjusted in conjunction with each other.

1. VDU monitors should have a mechanism to allow the monitor to be tilted. The recommended range of adjustment is from -5° to $+15^{\circ}$ (see figure 3). This is to allow the line of sight to be at right angles to the screen surface.
2. It should be possible to swivel the VDU monitor. A range of $\pm 45^{\circ}$ is recommended (see figure 4).



Figure 4
Recommended adjustability of the VDU monitor — plan view.

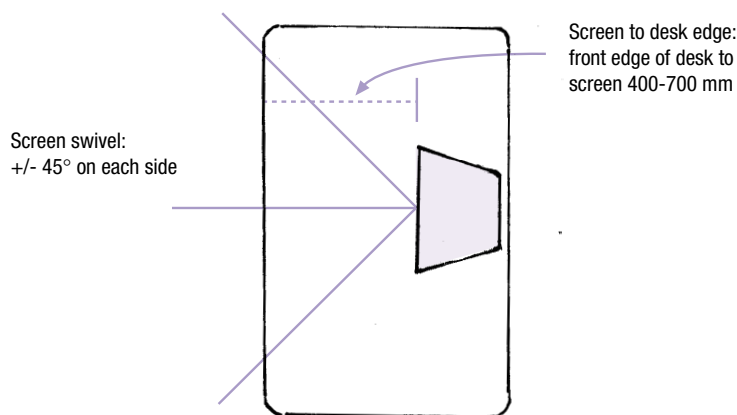

3. The distance of the VDU screen from the eyes should be adjustable for comfort. A recommended range is 450-800 mm — i.e. to about an arm's length. As a consequence, the distance from the front edge of the desk to the screen may need to be adjustable from 400 mm to 700 mm (see figure 4).

4. The height of the VDU monitor should be adjustable to suit the individual sitting at the desk. If the monitor is too low, discomfort may occur because the head is dropped forward. If the monitor is too high, discomfort may occur because the head is tilted backwards. Therefore, sufficient monitor height adjustment should be provided so that if people experience discomfort, they can experiment to find the height that will alleviate it. As a guide, use a screen viewing angle of between 10° and 30° below the horizontal line of vision to the screen centre (see figure 3). To achieve this you should be able to place the monitor directly on the desk, and be able to adjust it upwards so that the centre of the screen is 350 mm above the desk top.

VDU screens that fit under the desk may be used, as long as provision is made to reposition the screen higher (i.e. on top of the desk) to cater for any people who develop neck discomfort as a result of the steeper viewing angle, and as long as other aspects of this arrangement do not compromise health and safety.

- 5. Where the VDU monitor requires frequent repositioning, it should be possible to make the adjustments easily and while seated.
- 6. Any VDU support should be stable, for safety.

Of this list of six adjustments, 1 and 2 may be built into the monitor. An external means of providing them will be needed if they are not.

VDU monitor arms

Support arms for VDU monitors are one way of providing the required adjustability. They may be more useful in some circumstances than others — for example where a screen is shared by several people.

Electric and magnetic field strengths

All electrically-powered office equipment, including VDUs, generate magnetic fields.

A Swedish technical document, referred to as the “MPRII”, deals with the ergonomics of VDUs and the electric and magnetic fields they generate. The recommended values stated in it are based on what is currently achievable by manufacturers of VDUs. The document’s recommendations support the idea that exposure to electric and magnetic fields from VDUs ought not to be greater than from other office equipment².

The maximum value cited in the MPRII document for magnetic field strength is 0.25 microTesla, measured 500 mm from the monitor. Most currently available VDU monitors meet this recommendation.

Recommendations about reducing exposure to magnetic fields to a minimum appear in section 2.7 and there is more information about the issue in part 3.

KEYBOARD

Keyboards should have the following features:

1. The keyboard should be separate from the monitor.
2. The keyboard should be thin. The height at the “asdf...” row should be 30 mm or less.
3. The slope should be within the range of 0°-15°, and should be adjustable.
Some users prefer a “negative” keyboard slope. Here, an angled support is placed under the keyboard to allow it to slope “back”, and a built-in palm support is provided at the level of the spacebar.
4. The reflectivity of the keys should be low, to prevent reflections from overhead lighting.
5. The colour should be neutral.
6. There should be a feedback mechanism to indicate when the keystroke is successful — a tactile click is preferred.

THE MOUSE

A mouse should have the following features:

1. The size and design of the mouse should not require a cramped hand posture when gripping it.
2. The buttons on the mouse should be located so that they are not cramped for the fingers and hand.
3. The mouse and keyboard support surfaces should be flat and on the same level.
4. The control/response ratio of mouse movement to screen cursor movement should be adjustable, either through the mouse software or, on older machines, through the hardware.
5. The pressure required to click the buttons should be neither so great as to be tiring when used continuously, nor so small that it is too easy to activate the buttons in error.



6. It should be possible to change the position of the mouse and its pad so that variation in arm position can be obtained and so that left-handed users can be catered for.
7. The mouse should be maintainable so that, if the movement of the screen cursor becomes jerky, it can be corrected.

ALTERNATIVE INPUT DEVICES

There are a number of alternative input devices, especially for specialised applications. Trackballs and the “puck” used at the digitiser tablet are examples.

These devices are not covered directly here, but many of the principles stated for the mouse apply to them. Employers are required, under the Health and Safety in Employment Act, to give consideration to the health and safety aspects of the design of these devices, and to undertake a hazard identification and assessment of them from first principles.

PORTABLE COMPUTERS

Special problems may be associated with the use of laptop and notebook computers. They are designed for portability and use in the field. They are, however, often used at locations with a cramped workspace, unsuitable furniture and poor environmental characteristics.

They pose particular problems for prolonged use when the monitor and keyboard cannot be separated. This means that it is usually impossible to get comfortable eye-screen and hand-keyboard relationships simultaneously. In addition, many of the laptop keyboards are smaller than conventional keyboards (thus cramping the hands), and the display quality can make the screen hard to read in comparison with the conventional cathode ray tube.

Recommended features for laptops are:

1. Detachable keyboards — or the ability to plug the laptop into a conventional monitor.
2. The keyboard characteristics 2, 3, 4, 5 and 6, as described above in the section on keyboards.
3. A positive display (dark letters on a light background), to enhance readability. (Gas plasma displays, that have the reverse presentation, have adequate legibility.)
4. Light and durable enough to carry without undue strain.

In general, for the purpose of complying with the Health and Safety in Employment Act, you should treat laptop and notebook computers in the same way as a conventional VDU. Unless the portable computer follows the recommendations made in this code, you should not choose it for continuous use in a place of work.

SOFTWARE

Software should be designed to make it easy for VDU operators to use their equipment effectively. Shortcuts can be built into software to reduce the number of keystrokes required for tasks, and many programs allow “hot key” assignment of mouse functions. VDU users should be trained to use both of these techniques, if they wish, where they are available.

The way that functions are assigned to keys may require the extended use of particular keys or key combinations. This may cause problems if these keys are difficult to reach, or if an awkward hand posture is needed to reach them.

When purchasing software, employers are advised to examine the task(s) the users will perform and to attempt to match the software characteristics to the task.

Software is available that will interrupt operators every so often, and prompt them to take a break. This practice has been used successfully in some circumstances, but has advantages and disadvantages. Sometimes the interruptions are annoying and increase the stress they were designed to prevent. Software like this should be installed with care, after discussion with the users.

2.5 OFFICE FURNITURE

Office furniture should permit operators to work comfortably and efficiently for the range of tasks that they need to carry out.

To ensure that people can get comfortable at their workstations, consider the interactions between the workstation components.

A good physical fit should be provided between each user and the workstation, and a variety of healthy postures should be catered for. (The accompanying publication *How to Use Your VDU Safely* describes ways of maintaining a good body position, and is one basis for the recommendations here.)

Many businesses reorganise their work areas from time to time as business needs dictate. It is sensible to choose equipment that allows flexibility in the arrangement and rearrangement of workstations.

By careful selection and/or design of the computer equipment and workstation components, you should cater for left-handed users and operators with special needs. Examples are VDU users with a disability, pregnant women, very tall or very short people and people with vision problems.

GENERAL COMMENTS ON RECOMMENDATIONS

The practices recommended in this section are summarised in checklist 3 in the accompanying publication. This may be used as an aid to hazard identification.

It should be remembered that when several users work at the same VDU workstation, a greater degree of adjustability will be required.

Shared workstations

Where several users use the same VDU workstation it should be easily adjustable, as follows:



1. The desk height should be adjustable, from the seated position. If the desk height is not adjustable, the chair height should rise far enough for the comfort of the person using it, and a foot-rest should be provided, for the user to obtain a comfortable posture.
2. The monitor height, eye-screen distance and screen tilt should be easily adjustable, ideally from the seated position.
3. The keyboard position should be adjustable, in the fore-aft direction, from the seated position.

These recommendations reflect the requirement that people coming to a shared VDU workstation should be able to adjust it quickly to meet their own needs.

Where one person only uses a workstation

Where a single user operates a VDU at a particular workstation, the workstation should be adjustable as above. However, in these cases, it is acceptable to use tools to make the adjustments, and it is not necessary to have a workstation that is easily adjusted from the seated position.

For all VDU users

If a user cannot get comfortable at a non-adjustable desk once the chair height, foot-rest and monitor height have been optimised, then a height-adjustable desk may need to be provided.

RECOMMENDATIONS ABOUT OFFICE FURNITURE

The recommendations that follow are taken from checklists designed for the evaluation of office desks, chairs, foot-rests and copy-holders³.

Most of the recommendations here address the general situation and dimensions are stated as a guide only. This is because the checklists specify ways of providing comfort for a percentage of users only.

Generally, equipment of this nature is designed to cater for short and tall users, but it is not designed to cater for **very tall** and **very short** users. In some of the recommendations that follow it is appropriate to state dimensions precisely, and this is indicated.

THE DESK

The chair is the item of equipment in closest contact with the VDU user. However, the desk plays a major role in determining posture, and needs to be regarded as equally important.

Figure 5
Recommendations for office desk dimensions and leg space.

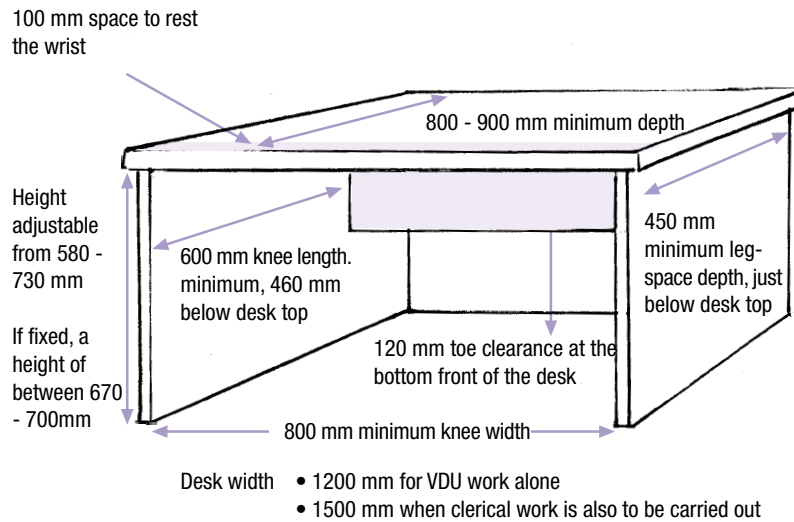

Recommendations for desks are:

1. The desk height should be adjustable to provide for operator comfort as follows:
 - Where different operators use the desk.
It may require frequent daily adjustment. The desk should be easily adjustable from 580 to 730 mm from the floor to the top surface of the desk, or an adjustable chair and footrest should be provided.
 - Where a single operator uses the desk all the time.
If the height of the desk is fixed it should be between 670 and 700mm from the floor to the top surface of the desk. When the desk height is not adjustable, provide a chair that rises sufficiently high for comfortable posture. Also provide a foot-rest if required.
2. The desk top should be as thin as possible — 30 mm or less. If possible, 26 mm.
3. The desk top should be deep enough — front to rear — to contain all the VDU equipment and to allow good posture. 800-900 mm will usually be required.
4. There should be sufficient leg space under the desk. (See figure 5.)
 - Knee width: 800 mm
 - Knee length: 450 mm, just below the desk top
 - Knee length: 600 mm, at 460 mm below the desk top
 - Toe space: 120 mm clearance between the bottom of the modesty panel and the floor, for the feet.
5. The desk top should be wide enough. A minimum width of 1200 mm where VDU work only is performed, and 1500 mm where the work has a clerical component as well, will usually be required.
6. The desk should be stable and strong.
7. The desk controls should be marked for function and direction, and be quiet and smooth in operation. They should also be designed so that they avoid injury, damage to clothing, accidental operation, or a tendency to wind down under gravity.

8. The upper and lower edges and corners of the desk should be rounded, to avoid injury.
9. The surface of the desk should be a light, neutral colour and be non-reflective.
10. A space of about 100 mm should be allowed on the front edge of the desk on which to rest the heel of the hand, or to place a wrist-rest.

This should not be used while keying.

11. There should be adequate space for the mouse and mouse pad (or other input device) on either side of the keyboard.

Keyboard supports

Keyboard supports on desks provide some flexibility in the provision of adjustability, and can have advantages for combined clerical and keyboard work. However, they can pose the following problems:

- The placement of the keyboard is restricted to one place.
- It may be impossible to align the alphanumeric key area with the screen centre.
- The mechanism may snag clothing.
- The keyboard support may be too short to accommodate the keyboard and mouse — this means that the mouse will have to be placed on the desk, requiring constant awkward reaching.
- The adjustment mechanism may compromise knee space.
- The adjustment mechanism may become unreliable over the 10-20 year life of the desk.

THE CHAIR

Chairs for VDU use should be adjustable to allow different users to obtain comfort and to allow a single operator a variety of postures. Special provisions may be required in particular circumstances; for example, where women are pregnant or where people are very short, tall, or have a disability.

Figure 6
Recommendations for adjustable office chairs.

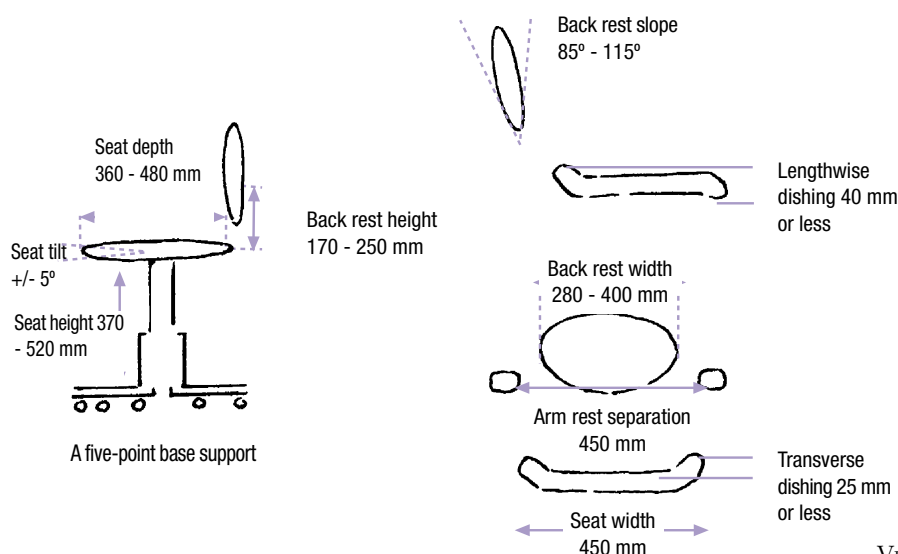

Recommendations for office chairs are:

1. The depth of the chair should allow a comfortable leg and back posture. The recommended depth is 380-480 mm (see figure 6).
2. The seat pan should be wide enough for the person. The recommended minimum width is 450 mm (see figure 6).
3. The chair should be adjustable for height, backrest angle and backrest height. The controls should be easily operable from the seated position.
4. The chair height should suit the person(s) using the workstation. A seat height range of from 370 to 520 mm could be required to accommodate several people of widely different heights. It is difficult to find this degree of adjustment in one chair (because the gas stem travel is typically limited to 125 mm). Chairs with different ranges of adjustment may therefore need to be purchased (see figure 6).
5. The backrest height should be adjustable to suit the individual. A range of 170-250 mm is recommended. (The backrest height is the distance from the seat pan to the centre point of the lumbar support area — see figure 6.)
6. The backrest angle should be adjustable to suit the individual. A range of 85°-115° to the horizontal is recommended (see figure 6).
7. Expert opinion is divided on the optimum seat pan angle. Some say that the seat pan angle ought to slope back slightly to push the back on to the backrest. Others promote a seat pan that has no slope, or even a slight forward tilt to allow some body weight to be taken by the feet.
An ideal chair will allow a person to find their own comfortable position. To permit this, a seat tilt range of -5° to +5° is appropriate, but this adjustment is not essential (see figure 6).
If fixed, seat angle should be within 5° of the horizontal.
8. The front edge of the seat pan should not interfere with the thighs and calves. (A “waterfall” front edge is recommended.)
9. The chair should swivel through 360°.
10. The backrest should not interfere with the elbows. The recommended width is 280-400 mm. Some slender people may not be suited by the upper range (see figure 6).
11. Armrests should not be too close together, or too high, or they will interfere with the elbows. Armrests should be designed so that the chair can be drawn up to the desk. They can be set back from the front of the chair or set low, or both. It is recommended that armrests be removable and that they have no sharp edges.
12. Cushioning should be soft enough to be comfortable, but firm enough to provide support for a variety of postures. Fabric should allow heat and perspiration to escape. For this reason, the use of vinyl is not recommended.
13. The chair design should have no sharp edges.
14. The chair should be stable. Five base support points are recommended.



15. The chair should move easily on carpet, but not too easily on a hard floor. Castors are recommended. Castors with “built-in friction” will prevent a chair from rolling uncontrollably on a hard (vinyl) floor.
16. The build-up of static charge can be a problem at the VDU workstation. It can be minimised by appropriate selection of fabric, castors and carpets (and the maintenance of humidity).

THE FOOT-REST

Where the desk and chair cannot be adjusted to provide optimum comfort, a foot-rest may be useful. When feet would otherwise dangle, foot-rests are useful to restore proper posture. The support they provide affects the posture of the entire body, including the lower back and neck.

Figure 7
Recommended dimensions of foot-rests

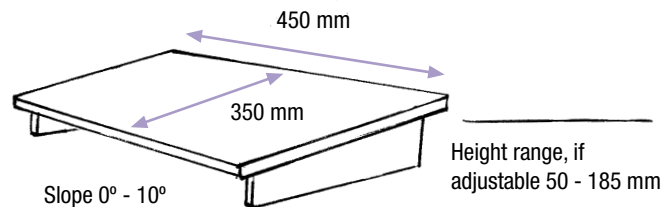

Recommendations for the foot-rest are:

1. The foot-rest surface should be large enough to provide for variation in foot position. The recommended minimum dimensions are 350 by 450 mm. The foot-rest should be flat across its surface. The surface should be of high friction so the feet can't slip off it.
2. The foot-rest should not weigh so much that it is awkward to re-position when required.
3. If fixed in height, the height of the foot-rest should be suited to the person in that workstation. If adjustable in height, a range of 50-185 mm is recommended. When a person works at a high bench, a height adjustment range of 135-415 mm is recommended for the foot-rest. If adjustable in steps, the height increments should be 50 mm or less.
4. The foot-rest slope should be comfortable for the user. A slope of 0°-10° is recommended. When the foot-rest is adjustable for slope, increments of 4° or less are recommended.
5. Movements of and adjustments to the foot-rest should be possible from the seated position — safely, and preferably with the feet.
6. The height and slope should be adjustable independently.
7. The foot-rest should be stable and not slide easily on the floor.
8. Where the VDU user operates a dictaphone with foot controls, the foot control should be built in to the foot-rest and attached firmly to it. The top of each control should be flush with the foot-rest surface, so that awkward postures due to holding the toes up are avoided.

9. Where VDU users do paper work also, or work at two desks at different heights, the foot-rest may need to be height-adjustable or they may need two footrests of different heights.
10. Wearing high-heeled shoes may affect the ability to obtain a comfortable foot posture.

THE COPY-HOLDER

Copy-holders make it possible to view documents without excessive neck bending and are recommended for use wherever possible. The copy-holder needs to be suited to the particular task. Some general recommendations are:

1. The copy-holder should be large enough to support the copy placed on it.
2. The copy-holder should be positioned, relative to the VDU monitor and other visual tasks, so that it is comfortable for the user (see figure 8).
3. The copy-holder should be stable in all positions. It should be able to support the weight of any items likely to be placed on it, without loss of the set position, including any heavy books that are used.

Figure 8
Placement of keyboard, monitor and copy-holders

Plan view

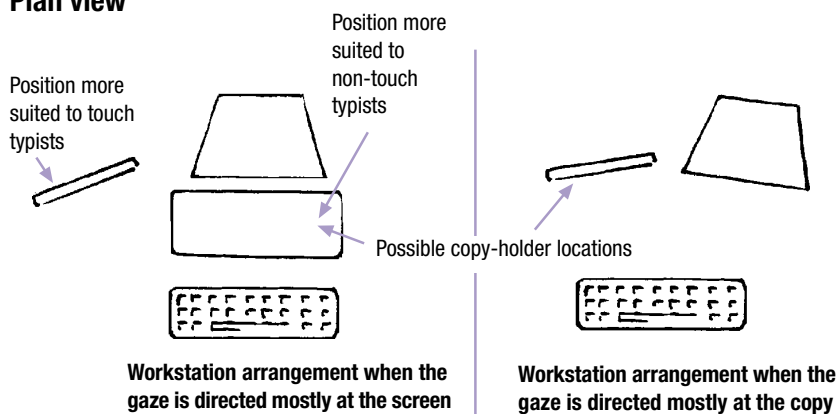

WRIST-RESTS

Wrist-rests are designed to reduce sustained tension in the muscle tissues of the top of the forearm. This is usually caused when the hands are bent up too far at the wrist while using the keyboard.

(Refer to the publication *Using Your VDU Safely* for further details about wrist posture.)

A wrist-rest is designed for use only when resting between bouts of keying. The underside of the wrist is delicate, with tendons close to the surface. Too much contact between the wrist and the wrist-rest may cause problems

through too much pressure. A possible danger of wrist-rests is that the shoulders will be held raised if the wrist-rest is too high.

There are a variety of wrist-rests available. Check for the following recommended features:

1. Height To suit the user (about space bar height).
2. Width About 75–100 mm.
3. Length To extend the full length of the keyboard.
4. Sponginess Not so soft as to constrain the hand position.
5. Position Should be easily variable to suit the user and task.
6. Slipperiness Adequate to allow free hand/palm movement.

VDU users should be trained in the correct use of wrist-rests.

DESK-MOUNTED ARM SUPPORTS

Arm supports clip on to the desk and, through a height-adjustable cantilever mechanism, support the forearms.

Laboratory testing has shown that tension of certain muscles in the shoulder area is reduced when using arm supports. Therefore they may, in theory, result in less discomfort. If they are used incorrectly, they may increase discomfort — for example, if the shoulders are raised or the or if the forearms are held forward. VDU users who use an arm support will therefore need instruction in their correct use.

Evidence of the ability of arm supports to reduce any discomfort experienced by VDU users is so far anecdotal, though many in the rehabilitation field speak highly of their use in getting people with occupational overuse syndrome back to work.

VDU users should be trained in the correct use of arm supports.

TELEPHONE HEADSETS

VDU users who need to talk on the telephone and key simultaneously should be provided with headsets so that both hands are free to operate the keyboard. This prevents the need to cradle the telephone handset between the ear and the shoulder — a practice that has caused cases of occupational overuse syndrome. Headsets are available in a variety of styles, and the user's preference should be recognised.

WHEN VDU USERS STAND TO WORK

Sometimes VDU users work while standing.

There is no objection to standing to use a VDU, apart from the kinds of problems that may arise when people are on their feet all day.

(Many people with back pain find standing to be a more comfortable way to work.)

Recommendations for VDU users who stand to work include:

1. Sufficient space behind and to the side to be able to move freely.
2. A floor that is even and free from tripping hazards.
3. A screen that is adjustable, as recommended above.
4. A keyboard at a height that allows a comfortable arm posture.
5. The provision of a chair for prolonged work. A sit-stand seat (see figure 9) will be more supportive than a high office chair.
6. A foot-rest that allows the user to raise one foot off the ground to provide some relief from the effects of a static posture. A foot-rest will be essential if a high office chair is to be used comfortably (see figure 9).

Figure 9
Standing work.

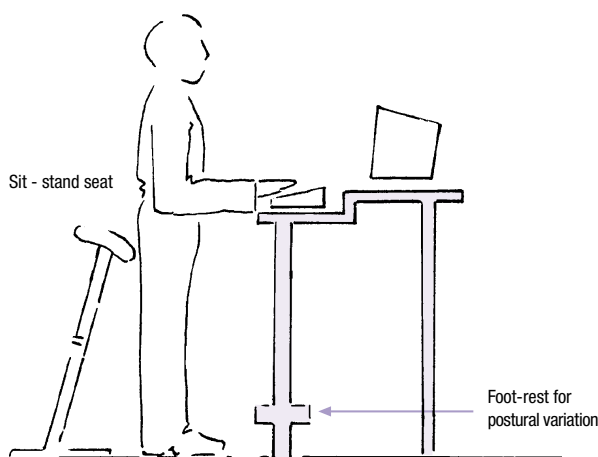

2.6 THE OFFICE ENVIRONMENT

The physical aspects of the office environment include:

- Space
- Housekeeping
- Thermal comfort — including temperature and humidity
- Ventilation
- Noise
- Visual conditions — lighting and decor.

Even if the office furniture and computer equipment are selected and arranged correctly, health problems may occur if these aspects of the working environment are poor.

SPACE

Each VDU user should have enough space to carry out their tasks safely. The amount of space needed will depend on the nature of the task and on the



equipment and furniture that is being used. Other criteria that you should use in determining the amount of space required include the need for movement, such as access to the workstation and the need to open filing cabinets and desk drawers.

HOUSEKEEPING

Good housekeeping is a standard safety and health practice. In the office where VDUs are used, this means keeping floors tidy and safe. Drawers on filing cabinets and desks should be kept closed, to prevent collisions. Heavy drawers, if left open, may cause a filing cabinet to overbalance.

Cables leading to and from computers should be arranged to avoid a tripping hazard to anyone walking past. Good housekeeping principles apply.

ATMOSPHERIC CONDITIONS

Temperature and humidity

The ambient temperature, the humidity, the speed of air movement and radiant sources of heat all contribute to thermal comfort. Air temperature alone is therefore unable, by itself, to indicate if a person will be comfortable.

A comfortable temperature seems to be about 17-22°C, but this may vary from summer to winter. This may be interpreted to mean that a temperature in this range will lead to the fewest complaints. Moderate humidity (45-75%), moderate air movement (0.01 to 0.02 metres/sec) and “pure” air (about 10 litres per person per second in a normal office) are also recommended. These qualities of the thermal environment are inevitably related to comfort. Drafts of cold air may pose a direct risk for occupational overuse syndrome.

Ventilation

People react strongly when they perceive that the air is stuffy, stale or polluted. Their reaction may be expressed as general dissatisfaction with the environment. Sources of pollution in buildings may be internal, external or structural. People release the greatest amount of pollutants, in the form of substances such as methane, carbon dioxide, ammonia and hydrogen sulphide. Office machinery and fittings, such as photocopiers and laser printers, carpets, wall coverings, particle board, and cleaning materials may emit a variety of substances such as ozone, formaldehyde and solvent vapours. Tobacco smoke may also be an issue.

Natural or mechanical ventilation will be needed to remove all of these substances.

When buildings are air conditioned, expert advice may be needed to resolve problems of stuffiness. The New Zealand standard⁴, and any applicable local codes, should be followed.

Laser printers and photocopiers

The large amounts of heat produced by VDUs, laser printers and photocopiers, especially large ones, may be responsible for symptoms of dryness in the throat. These devices may also generate ozone.

Photocopiers, especially large ones, are relatively noisier than printers. VDU users who sit near photocopiers and printers may be distracted by the constant

coming and going of other people. They should be located far enough away to avoid these problems.

Regular maintenance should be carried out on both photocopiers and laser printers, as recommended by the supplier. Drafts created by photocopiers and laser printers may cause problems for VDU users if they sit in the direct path of the air outlet.

NOISE

Printers, especially of the dot-matrix kind, and fans are the main sources of noise associated with VDU work. This noise, which can reach levels that are irritating or distracting, can affect health and productivity.

Stress levels can be influenced by the amount and type of noise in the office. Noise in offices is unlikely, in most cases, to reach levels that are hazardous to hearing, but there have been some reports where noise levels in offices have exceeded 85 dBA.

Noise is a special problem in open plan offices, with common complaints about interference from nearby conversations and telephones. Special problems arise when the noise has a particular quality. The throbbing of a ventilation duct need not be very loud to be very annoying, for example.

Measures to reduce noise

Standard methods of controlling noise include:

- Padding under machines;
- Enclosure of noisy machines in acoustic hoods;
- Carpet on the floor;
- Sound-absorbing partitions;
- Acoustic ceiling tiles; and
- The replacement, isolation or relocation of noisy equipment.

A background level of 55dBA — 'Leq' or the average level — at the operator position may be regarded as an upper limit, but the aim should be for a lower level such as 35 dBA. If the noise level is much higher than this, people will report annoyance and communication problems. An Australian standard offers guidance here⁵.

LIGHTING

Light levels that suit the situation should be provided. The normally recommended illuminance at clerical workstations (for doing paper work) is 500 lux, although higher levels up to 700 lux are acceptable in some situations.

At the VDU workstation, different levels of illumination may be required, depending upon the nature of the work being performed, the polarity of the VDU display and on the surroundings, as set out below.

Negative displays

When the VDU displays a bright image on a dark background (referred to as a negative display), illumination on the desk of 200 to 350 lux is recommended, as long as hard copy (text on paper) is not in use.



Positive displays

When the VDU displays a dark image on a white background (referred to as a positive display), illumination of up to 500 lux on the desk is recommended. (Positive displays, introduced to promote ease of use of the software, are becoming more common with the increased use of software applications such as “Windows”. These, and Macintosh programmes, have dark letters on a bright background.)

Lighting copy

When hard copy is used, text on paper must be clearly readable. This is difficult when the illumination drops to 200-300 lux, particularly for older workers. Task lighting is often recommended in this situation, but is difficult to provide so that large brightness differences between the screen and the copy are avoided. Therefore, when hard copy must be used with a VDU that displays a bright image on a dark background, illumination on the desk of 300-350 lux is recommended. This is a compromise between the ease of reading text on paper and avoiding glare on the screen. If the illumination is above this amount, then a glare filter placed over the screen may be helpful.

It is important to note that these subtleties will be more important to some (generally older) people. Other people, however, will display more tolerance to visual conditions that are not perfect. Each circumstance should therefore be treated on its own merits.

Reflection and glare

The two main visual problems for VDU users are screen reflections, and direct glare from bright lights in the field of view.

Reflections in the VDU screen should be prevented. They are most frequently caused by poor placement of the monitor in relation to windows and bright lights. Reflections can be avoided by placing the VDU correctly. Where possible, the screen should be at right angles to the window or source of bright light.

If it is not possible to place the VDU in a position without reflections occurring in the screen, then additional control measures may be necessary, such as raising the monitor, tilting the face of the VDU screen downwards, or the use of efficient curtaining. See also figures 10 and 11.

Figure 10
Placement of VDU to avoid screen reflections.

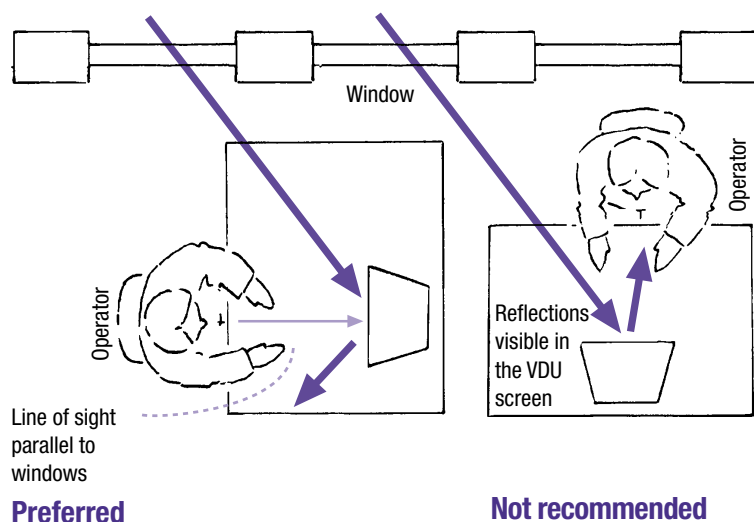

To avoid direct glare, the VDU should be positioned so that the user does not face directly into a bright light, such as direct sunlight from a window or a bright artificial light source. Preventing glare from the sun may mean relocating the VDU monitor or using effective window coverings.

Figure 11
Placement of VDU to avoid glare.

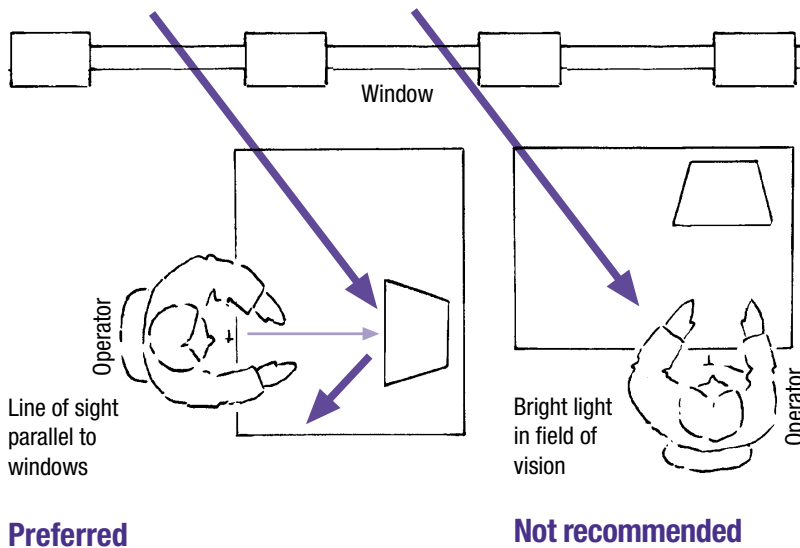

Preferred

Not recommended

There are “glare-free” luminaires specifically designed for VDU use. Where existing light fixtures are unsuitable and cannot be replaced, fitting fire resistant baffles around them may prevent unwanted reflections.

Overhead lighting should not be placed in the “offending zone” (see figure 12(i) or directly behind the user (see figure 12(ii)). Where fluorescent lighting is installed, the long axis of the fitting should be parallel to the line of vision. With this arrangement, light fittings will cause minimal reflections and glare, as shown in figure 13.

Figure 12
Poor luminaire placement.
(i) The “offending zone”

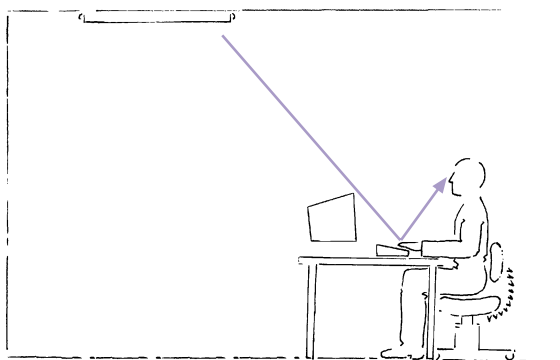

Not recommended

This light is located in the 'offending zone'.

Light from it will be reflected from the desk into the operator's eyes.

(ii) A placement that causes reflections in the screen.

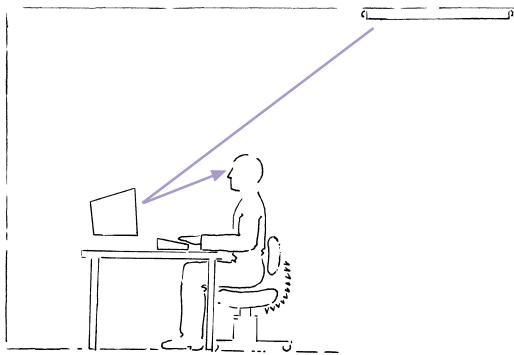

Not recommended

This luminaire is poorly located.

Light from it will be reflected from the VDU screen into the operator's eyes.

In many offices the luminaires are arranged in a regular pattern on the ceiling. VDUs, however, may be positioned in non-regular or random groupings. When this happens, it is not possible to place every VDU in the optimal position in relation to light fittings and windows. Here, measures will need to be taken to screen those light sources that cause reflections or glare.

Figure 13
Good luminaire placement.

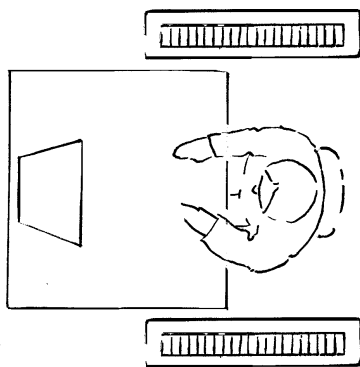

Preferred

Plan view
Light from the fixtures cannot be reflected.

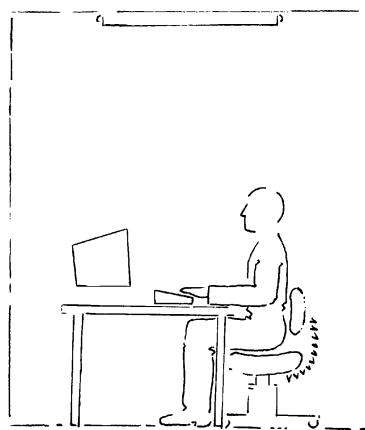

Preferred

Elevation
Luminaire is placed level with the operator.

Glare filters

Screen glare filters provide a remedy for the problem of reflections in the screen, but not for direct glare. It is preferable to try the solutions mentioned above before using glare filters.

Local lighting

Local lighting may be required, in certain circumstances, to throw enough light on copy. Local lighting tends to cause reflections in the screens of other VDU users, and to create heat, and requires careful placement. It is preferable to try the other solutions mentioned before using local lighting.

Maintenance of lighting

Office lighting should be maintained so the light output does not lessen over time. This means cleaning the lamps and luminaires regularly and replacing fluorescent tubes as they age beyond their design life.

DECOR

Decor is an integral part of the office lighting and should be planned along with it.

Extremes of brightness contrast in the field of view of a VDU operator are very common but should be prevented. An example of an extreme brightness contrast is when a white wall and a dark ceiling meet. If colours used in the decor are too dark, brightness contrasts are likely, and more energy will be required to provide enough illumination. This is because dark surfaces do not reflect light as well as lighter surfaces. The reflectances of room surfaces should be as recommended in figure 14. Interior designers should consider this aspect of decor at the design stage.

Figure 14
Recommended room surface reflectances.

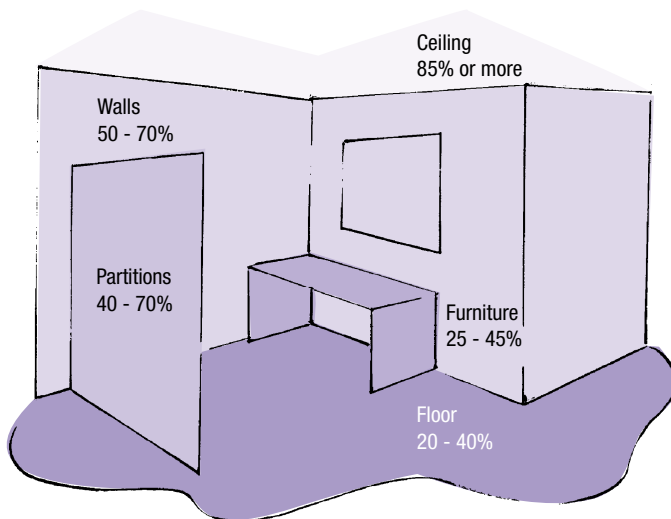

2.7 ARRANGING THE HARDWARE AND FURNITURE

Even when components and the physical aspects of the working environment have been carefully selected and designed, there will be little advantage if they are poorly arranged and located.

Recommendations about these two aspects of workstation layout — the arrangement of the equipment on the desk, and the placement of the desk in the room — bring together the recommendations already made.

LOCATION OF ITEMS ON THE DESK

You will need to think in advance about where the items required at the workstation will be placed on it. Figure 15 illustrates the basic principles of placing frequently used items within easy reach. There are many other possible arrangements. An alternative layout is shown in figure 16.

Note that for optimum comfort:

- The screen should be from 450-800 mm from the eyes, depending on the operator's preference.
- The copyholder should be located for comfortable viewing.
- You may need a space of 100 mm between the keyboard and the desk edge to rest your wrists on.

Figure 15
Workstation arrangement.

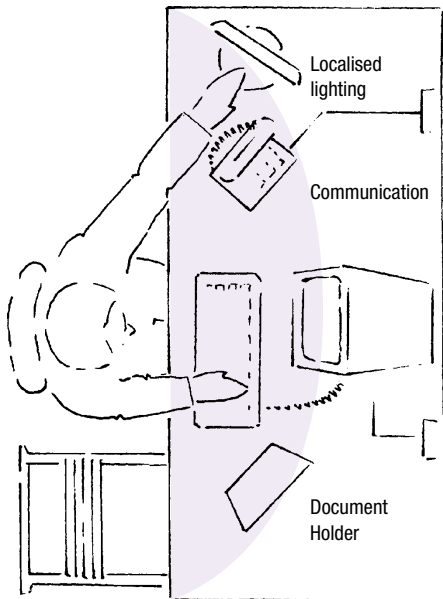

Reach envelope

LOCATING THE DESK AND EQUIPMENT

A workstation that is arranged for optimum efficiency and comfort in all other respects may lead VDU users into keeping still for too long. This is undesirable, as people naturally need to move around for breaks and exercise. The position of the desk in the office should therefore not impede getting into and out of the chair. Filing cabinets should be placed so that they are within easy reach and so that they do not block passages when a drawer is open. To reduce exposure to magnetic fields to a minimum, the following are recommended:

- Keep the monitor at arm's length.
- Keep two arms' length from other people's monitors.

- Keep printers (and other office electrical devices) at arm's length.
- Place wiring — trunk cabling and switchboards — so as to minimise worker exposure to electric and magnetic fields.

Figure 16
Good workstation arrangement at an “L-return” desk.

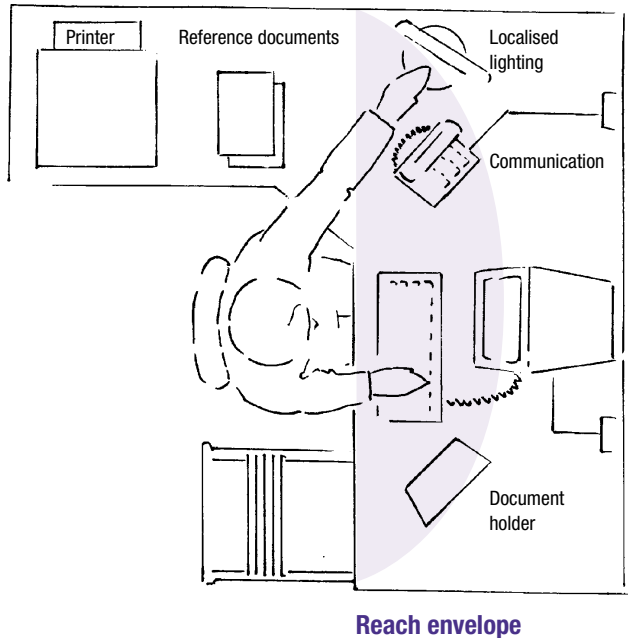

Unless the design of the desk allows the arms to be free of interference with the edges of the desk, the keyboard should not be placed in the angle between the desk and return. A triangular keyboard support should be placed between the two desks if the screen is placed in the desk angle.

2.8 HAZARD NOTIFICATION AND TRAINING

Employers must give employees using VDUs:

- Information about all the identified hazards they face;
- Information about the steps taken to minimise the likelihood that these hazards will be a source of harm;
- Information about the hazards that they may create during work, and how to minimise the likelihood that the hazards created will be a source of harm; and
- Adequate training in the safe use of the equipment.

These requirements suggest that information and training must cover at least these aspects of VDU work:

Information about hazards (see part 3)

- Occupational overuse syndrome;
- Visual and ocular discomfort;
- Stress;

- Skin problems;
- Photogenic epilepsy; and
- Health issues associated with electromagnetic fields.

The Health and Safety in Employment Act requires that information about hazards is given to employees in a form and manner that employees are reasonably likely to understand.

Training about working safely

- *The use, maintenance and adjustment of computer equipment, chairs and furniture;*
- *Body skills:* posture, relaxation, working techniques, micropauses, taking breaks, and exercises;
- *Work organisation:* scheduling work to avoid peak pressures and repeated urgent deadlines;
- *Software:* training in the use of software, to promote efficiency and avoid frustration; and
- Training in fundamental *keyboard skills*.

The Health and Safety in Employment Act requires that each employee is “adequately trained” in the safe use of all the plant, objects, substances, and protective clothing and equipment that the employee is or may be required to use or handle.

What does “adequately trained” mean?

The object of training is to ensure, so far as training is able, that each VDU user is able to carry out tasks without causing harm to themselves or anyone else.

An employee may fail to understand the training. Therefore, an employer should monitor each employee’s reaction to the training until he or she can put the objects of the training into practice.

Training is only a part of the defence against harm. Unless other measures are taken — such as good design of furniture, lighting and equipment, and the maintenance of reasonable levels of work outlined in sections 2.3 to 2.7 of this code — employees may not be able to practice safe habits, such as good working techniques or adopting safe postures.

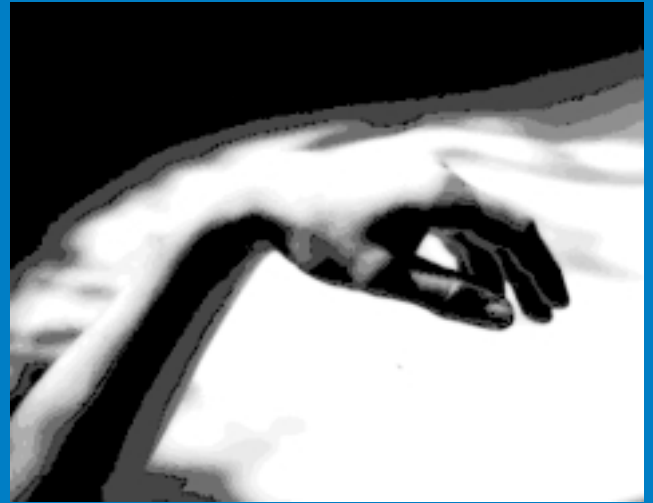

PART 3

HEALTH PROBLEMS OF VDU WORK

THIS PART CONTAINS

- 3.1 Health problems* 44
- 3.2 Health monitoring* 48

Section 3.1 discusses concerns about six health problems that are often raised in connection with VDU use. Section 3.2 discusses the actions employers should take to monitor exposure to hazards that may lead to these problems and to monitor employee health.

Experience so far indicates that the longer the period a VDU user spends each day at a VDU, then the more likely the person is to experience postural problems, aches and pains, visual discomfort and stress.

The other health problems mentioned are very unlikely to result from VDU use.

3.1 HEALTH PROBLEMS

OCCUPATIONAL OVERUSE SYNDROME

Occupational overuse syndrome (OOS) is a collective term for a range of conditions — including injury — characterised by discomfort or pain in the muscles, tendons and other soft tissues, with or without physical signs. The symptoms of OOS can include:

- Fatigue;
- Muscle discomfort;
- A burning sensation;
- Stiffness;
- Aches and pains;
- Soreness;
- Weakness; or
- Numbness and tingling.

Every case of OOS has the potential to be classified as “serious harm” according to the definition in the first schedule of the Health and Safety in Employment Act. This is because it can lead to injury resulting in absence from work for extended periods and temporary severe loss of bodily function. This also means that the risk factors for OOS need to be treated as significant hazards.

The risk factors for OOS, which are addressed in part 2 of this code, can be summarised as:

- Poor planning for VDU work;
- Poor work organisation;
- Inappropriate selection of computer hardware and software;
- Inappropriate selection of office furniture;
- An inappropriate VDU environment;
- Poor workstation layout; and
- A lack of education, training and skills.

One or more of these risk factors will almost certainly be present where OOS occurs. But the nature of OOS is such that individuals may be affected differently by these risk factors. There may be a relation between the intensity of work, the length of exposure to it, and the onset of the condition. But it is not possible to predict exactly what it will be for a particular person.

This means that when assessing an individual, the assessment needs to be carried out in relation to each individual’s situation. This situation may include aspects of life outside work, such as secondary employment, hobbies, sports or crafts. Sometimes OOS can be precipitated or made worse by these activities.



VISUAL AND OCULAR DISCOMFORT

Visual and ocular discomfort can show a variety of symptoms. These include:

- Soreness of the eyes;
- Reddening of the eyes;
- Watering or dryness of the eyes;
- Blurring of vision;
- Eyes feeling “heavy” or “gritty”; and
- Headaches.

Visual and ocular discomfort is very unlikely to reach the point where it could be described as serious harm (see below).

The consequences of this for monitoring are explained in section 3.2.

VDU users tend to have a fixed distance and angle of gaze. Typically, the point of focus is about 600 mm away. This requires that the internal eye muscles that focus and fix the point of vision hold the same position for long periods. Like any muscles, the ones in the eye need to relax.

A VDU cannot be moved about like a book, and therefore the eyes need to move very little to maintain clear viewing. This, in turn, requires that the VDU user's posture remain fixed.

These two factors — the constant holding of the eye, head, neck and shoulder in fixed positions and the constant focus and fixed point of gaze — are thought to be the main contributors to visual and ocular discomfort.

Several scientific studies have compared the vision of VDU users and clerical workers over several years. They have shown that, in the long term, VDU use does not cause a more rapid deterioration of VDU users' vision.

Other causes of visual and ocular discomfort may be:

- Uncorrected visual anomalies;
- An inappropriate glasses or contact lens prescription;
- Poor office furniture selection and/or design; or
- Inadequate lighting.

Such symptoms may also result from alterations in the way the eye produces the tear film on the surface of the eyeball, perhaps compounded by excessive heat or low humidity.

STRESS

It is important to note that “stress” is the reaction of the person to either internal or external pressures or “stressors” or both (see figure 17).

Figure 17
Stress is the reaction.

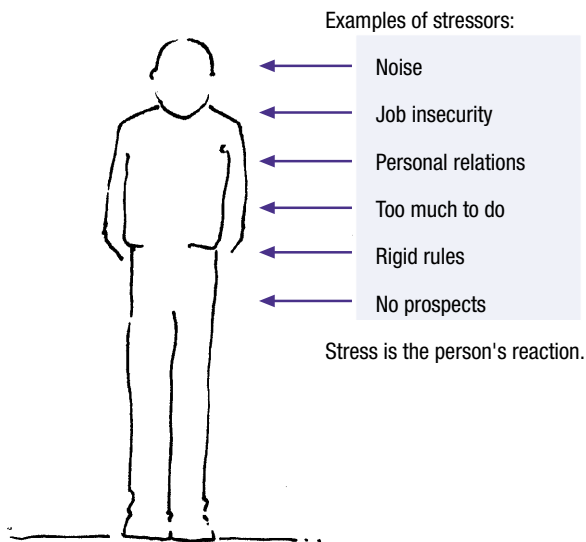

Stress, muscular aches and pains, and visual and ocular discomfort arising from VDU work are inevitably interlinked. Particular reasons that VDU users might experience stress as a result of their work — rather than from general causes — are to do with the intensity that VDU work can reach, social isolation, the reaction of some personalities to VDU work, and the failure to take breaks.

Stress may be defined in many ways. A useful definition relating to VDU use is simply “being alert for too long”.

A particular aspect of much VDU work is that it can go on for a long time without interruption. Often, people need to meet strict deadlines or get carried away with the work they are doing, and are unable or forget to get relief from the intensity of it.

Sometimes the nature of the work at the VDU is “isolating”. The absence of workplace interactions can increase the stress of VDU work.

All these factors indicate the need for care in the design of VDU tasks.

PHOTOGENIC EPILEPSY

Photogenic epilepsy is a rare condition that affects one person in between 4,000 and 8,000. People susceptible in this way can experience epileptic attacks triggered by exposure to flickering light. The likelihood that a susceptible person will experience an attack depends on a number of factors, including the sex and age of the person, the frequency of the flicker, and the intensity and size of the source. The peak onset age of this condition is about 12 years, and the condition is twice as common in women as in men.

It is therefore likely that most people liable to epileptic attacks in this way will know of their susceptibility by the time they begin VDU work. VDU monitors have a refresh (flicker) rate that is well above the optimum



frequency for triggering an attack. The relatively low brightness of the VDU screen, its small size and the other factors mentioned make the chance of such an attack during VDU work very unlikely.

SKIN PROBLEMS

Skin problems in VDU operators are reported from time to time. Scientific investigation of dermatitis and other skin problems experienced by VDU operators has not revealed any consistent pattern of association with VDU use. Although a number of theories have been advanced, specialists are agreed that there is, as yet, no convincing explanation of why dermatitis might occur more frequently in VDU users, apart from the tendency of VDUs to dry the air and create static fields. Further investigations are being conducted.

HEALTH ISSUES ASSOCIATED WITH ELECTROMAGNETIC FIELDS

The relationships between the above conditions and VDU use are relatively clear cut. More difficult to resolve are health issues related to the electric and magnetic fields generated by VDU monitors. Of these two types of field, it is widely agreed that questions remain only about magnetic fields.

Many scientific studies have been conducted to find an answer to the question: "Do the magnetic fields generated by VDUs pose a hazard to health?" Most have shown no association between exposure to VDUs and health outcomes.

Authors of a recent publication produced by the International Labour Office reviewed the results from these studies and made the following comments:

In conclusion, and based on current biomedical knowledge, there are no health hazards associated with radiation or fields from VDUs. Thus, there is no scientific basis to justify shielding or radiation monitoring for VDUs.

However, since a large number of people are involved in VDU work, it is important that further knowledge is attained on certain areas where our knowledge must be regarded as incomplete.⁶

The document discusses two areas that fall into the category of incomplete knowledge: skin disorders, and the possibility of interactions between biological systems and low-frequency magnetic fields.

On the basis of this information, there should be no major concern about the electric and magnetic fields generated by VDUs. However, given the areas of "incomplete knowledge" referred to, it is sensible to pursue a policy of prudent avoidance to ensure that exposure to these fields is minimised.

The electromagnetic field strengths typically generated by VDU monitors are in the order of 0.15 microTesla, well below the levels identified as "reasonably achievable" in the MPRII standard². Tests carried out by the New Zealand National Radiation Laboratory showed that only 2 of 46 monitors tested exceeded this value. The two that were above this limit were below 0.3 microTesla⁷.

MISCARRIAGES

There is no consistent, conclusive evidence from scientific studies that VDU work by pregnant women can result in miscarriages. Nonetheless, many people remain concerned that VDU work might result in miscarriages.

Interest in this topic was initiated when four pregnant operators at a newspaper office in Toronto, Canada, experienced miscarriages shortly after the introduction of VDUs. Similar clusters of miscarriages have since been reported. The World Health Organisation has concluded that these clusters are almost certainly the result of other factors or chance⁸.

Since this incident, several large studies have been conducted investigating the association between VDU use by pregnant women and their pregnancy outcomes. In only two of these studies was a significant association found, but examination of the data presented in these two studies shows no evidence of a causal link between VDU use and miscarriages. The authors of one study, where an increased rate of miscarriage was found, suggested the result may have been due to fixed posture recall bias and other factors. Further studies on this issue are being carried out.

FOETAL ABNORMALITIES

Along with the question of miscarriages, the question of whether babies with birth defects born to VDU users are the result of the VDU use, has been examined in a series of large studies. They have not revealed an association between VDU use and this outcome.

OTHER HEALTH EFFECTS OF ELECTROMAGNETIC FIELDS

Studies have been conducted to explore the relationship between health effects such as brain cancer and leukaemia and exposure to electromagnetic fields generated by VDUs. Again, there is no clear, consistent epidemiological evidence that there is an association.

The field strengths that are experienced by VDU users are markedly smaller than those experienced by other groups where there has been more convincing, though not conclusive, evidence of an association.

3.2 HEALTH MONITORING

In VDU work, many of the hazards arise from the interaction of employees with their equipment. This means that the isolation or elimination of these hazards is often impossible.

If an employee faces a significant hazard, and if it cannot be eliminated or isolated, the Health and Safety in Employment Act requires that an employer must, in addition to minimising the hazard, monitor:

- a) the exposure of the employee to the hazard; and
- b) with the employee's consent, their health in relation to the hazard.

In deciding whether or not monitoring is required for an employee, the



employer must then determine (preferably in consultation with the employee) whether or not the employee faces a significant hazard.

What follows therefore applies where a VDU user faces a significant hazard.

MONITORING THE EXPOSURE TO SIGNIFICANT HAZARDS.

If the VDU equipment is selected and the workstation is set up as recommended in this code, then the hazards posed by these aspects of VDU use can be taken to have been minimised. These hazards will require ongoing monitoring, especially after any changes to the workstation and equipment. (Checklist 3 in the accompanying publication can be used for this purpose.)

Another aspect of the design of VDU work is the way it is organised — the volume and nature of the work and so on. This is more changeable, and will require monitoring which is more likely to be ongoing and more frequent. (Checklist 2 in the accompanying publication can be used for this purpose.)

MONITORING EMPLOYEES' HEALTH

When a VDU user faces a significant hazard, employers must take all practicable steps to obtain the consent of the affected employees to monitor their health and then, with their consent, the employer must monitor their health (HSE Act S 10(2) d) and e) in relation to the hazard.

The main health problems of VDU use are occupational overuse syndrome and visual and ocular discomfort. The health of each employee deemed to face a significant hazard in relation to these two types of harm must be monitored. Ways of doing this are as follows:

Monitoring for overuse syndrome

Monitoring for overuse syndrome, because of the nature of the problem, should aim to detect its symptoms early. Early reporting of any aches and pains by employees to supervisors is appropriate, so that they can be dealt with promptly before they become severe or chronic.

Systems suitable for this monitoring are:

- a) The opportunity for VDU users to report aches and pains at any time through a self-report of discomfort questionnaire.
- b) Periodic interviews of VDU users by the organisation's occupational health staff.
- c) Periodic questionnaire surveys of VDU users.

The system selected should be appropriate to the circumstances faced by the VDU user. The first of these methods requires that a system for early reporting is set up, that employees are trained how to use it, that impediments to its use are removed and that a procedure is developed for dealing with reports of discomfort, aches and pains.

A standardised, anonymous questionnaire can be used for this purpose. An example — *Self report of discomfort and pain* — is available from OSH branch offices. This form may be used as is or may be adapted to meet an employer's needs, as long as it meets the requirements of the Privacy Act.

Another situation in which a questionnaire is useful is when a person with aches and pains needs to visit a doctor or the employer's occupational safety and health service. A sample questionnaire is shown in the OSH treatment guide for occupational overuse syndrome⁹.

Other OSH publications^{10,11} are recommended for advice to help prevent symptoms of OOS or remedy them if they do occur.

Monitoring for visual and ocular discomfort

A possible cause of visual and ocular discomfort is when a person does not wear corrective lenses (spectacles or contact lenses) when they should, or when the ones they do wear are inappropriate for VDU work.

It is unlikely that a VDU user will face a significant hazard with respect to visual and ocular discomfort. Under the HSE Act, the monitoring of health in relation to a hazard is required only when a person faces a significant hazard, and the monitoring of visual and ocular discomfort is therefore not otherwise mandatory.

Note that where VDU work is a normal part of an employee's job:

- (i) Employees whose vision is in the best possible state will be more productive.
- (ii) Some employers find it good staff relations to meet some or all of the costs of vision screening, and lenses if they are necessary.

We therefore strongly suggest that employers adopt a company policy to ensure that both existing and new employees do not experience ocular and visual discomfort so that:

- (i) Employees start work in the best possible visual circumstances.
- (ii) If any employees develop vision problems, they are identified and dealt with promptly.

A suggested model vision policy

- 1.** Employers should discuss and consult with VDU users about the length and intensity of VDU use that each person's job requires.
- 2.** Where employees are using VDU for most of their working day, or are doing highly intensive visual work for shorter periods, they should have a vision assessment before beginning the job. Vision screening should be carried out for this purpose by an appropriately qualified person. Visual conditions at the person's workplace should be assessed and any defects remedied before the person starts work. The employer should review the person's situation after a few weeks of work to find out if she or he is developing any symptoms of visual or ocular discomfort.
- 3.** Where the employee's VDU work is less intense, the employer should review the person's situation after a few weeks of work to find out if she or he is developing any symptoms of visual or ocular discomfort. If so, the employer should assess the visual conditions at the person's workplace and remedy any defects. If the person continues to experience symptoms of visual and ocular discomfort, then they should undergo an eye examination.
- 4.** If vision screening reveals visual problems, then an eye examination should be performed by an optometrist or an ophthalmologist.
- 5.** This policy should apply to all new employees and, when the policy is initiated, should be applied to all existing employees.



6. Vision deteriorates naturally with increasing age, especially over the age of 40, and periodic reassessments of vision should be carried out, as the optometrist directs. If more than one year has elapsed since a VDU user began wearing appropriate corrective lenses, and should they develop visual and ocular discomfort, then re-examination may be required, as above.

The New Zealand Association of Optometrists has a policy statement that amplifies some of these points and standard questionnaires for both the vision screening and the eye examination for VDU operators¹².

WHO SHOULD PAY FOR THIS HEALTH MONITORING?

Since this monitoring is a requirement of the Health and Safety in Employment Act, the employer should pay for it, if the employee faces a significant hazard and with the following qualifications.

Occupational overuse syndrome

For occupational overuse syndrome (OOS), an employer must monitor the health of VDU users in relation to this problem. If this fell to the company occupational health nurse or the human resources department to administer, the cost would be borne internally. If visits to a doctor were needed for this monitoring, then the employer should pay for them.

Visual and ocular discomfort

Given the provisions in the HSE Act, the question of who should pay for corrective lenses and spectacle frames is outside the scope of this document, if the employee did not face a significant hazard and/or when the employee required them for daily life.

If it can be shown that an employee faces a significant hazard with respect to visual and ocular discomfort, the employer should pay for the initial vision screening, the eye examination if required, and lenses and spectacles if required exclusively for VDU use (see section 10(2) b of the Health and Safety in Employment Act).

WHAT IF A VDU USER HAS DISCOMFORT BUT DOES NOT REPORT IT?

If, for some reason, a VDU user developed discomfort, failed to report it, and it developed to become serious harm, the employer might, in certain circumstances, be held liable. This would occur if it could be demonstrated that the employer had failed to take all practicable steps (such as are outlined in this code).

If an employer became aware that an employee had not reported discomfort when they should have, the reasons for the non-reporting should be investigated and all practicable steps must then be taken to ensure it did not recur.

Examples of practicable steps in this instance might be to ensure that the reporting procedures were adequate, that training about the correct procedures was adequate and that the information given to VDU users in relation to the hazards concerned was understood.

4.1 INTRODUCTION

The emphasis of the Health and Safety in Employment Act is that employers and others take responsibility for health and safety in places of work under their control. The ultimate purpose of any action addressing VDU health problems at work is the prevention of harm. The absence of harm is the test of any actions taken by employers, who are in the best position to monitor the effects of the preventive efforts they have initiated.

The following is a summary of the obligations imposed. The wording of the Act itself must be consulted in cases of doubt over how the Act applies in any particular case.

GENERAL DUTIES (SECTION 6)

The Act requires employers to take all practicable steps to ensure the safety and health of employees and others while at work.

SPECIFIC DUTIES (SECTION 6A-E)

Employers must take all practicable steps to:

- Provide and maintain a safe working environment;
- Provide and maintain facilities for the safety and health of employees;
- Ensure that machinery and equipment are safe for employees;
- Ensure that working arrangements are not hazardous to employees; and
- Provide procedures to deal with emergencies that may arise while people are at work.

HAZARD MANAGEMENT (SECTIONS 7 - 10)

The Act requires employers to have systems in place for identifying and controlling hazards.

Step 1: Identify hazards (section 7)

A hazard is an activity, situation, equipment or substance that can cause harm.

Step 2: Assess hazards (section 7)

Employers need to determine which hazards are likely to cause the most harm to people. The Act uses the term “significant hazard”.

A “significant hazard” is a cause or potential cause of:

- Serious harm — this includes death, serious injury or disease as defined in the first schedule to the Act;
- Harm — the severity of which depends on how often or how long a person is exposed to the hazard. (For example, exposure to noise over a long period causes gradual, and permanent, deafness.)
- Harm that can't be detected until a significant time after exposure has occurred. (For example, exposure to certain chemicals may cause health problems years later.)



Step 3: Control hazards (sections 8-10)

If the hazard is significant, the Act sets out the process that should be followed to control it.

Figure 18 outlines the required steps.

Figure 18
Employer's duties once a significant hazard is identified

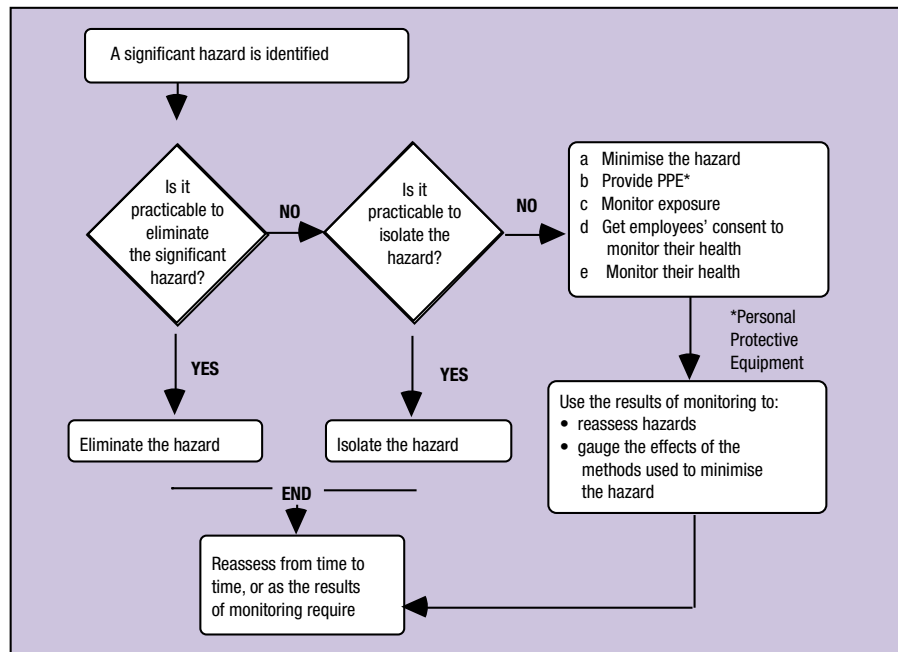

In short, a significant hazard should be eliminated (section 8), isolated (section 9) or minimised (section 10).

Employers must eliminate a significant hazard if it is reasonably practicable to do so. If not, employers must isolate the significant hazard, unless it is not reasonably practicable. When a significant hazard is minimised, additional responsibilities fall to the employer, as shown by figure 18.

4.2 APPLICATION OF THIS CODE

The recommendations set out in part 2 of this code explain how to find and deal with the hazards of VDU work. The recommendations are made on the basis of current knowledge about the problems associated with VDU work. If you follow the recommended actions in this part of the code, you would most likely meet your obligations under the Act.

4.3 INFORMING AND TRAINING EMPLOYEES

The Health and Safety in Employment Act requires that employees are given information about all the hazards in the place of work. The information must be given in a manner that the employee is reasonably likely to understand (section 12).

Training for employees must cover significant hazards and must be adequate (section 13). Suggestions for the type and content of the information and training for VDU users are listed in section 2.8 of this code.

4.4 ACCIDENT REPORTING AND RECORDING

Employers must maintain a register of accidents and serious harm, on a prescribed form (section 25 of the Act). All serious harm should be reported to the Occupational Safety and Health Service of the Department of Labour (OSH) as soon as possible after the occurrence, with a follow-up written report, in the prescribed form, within 7 days.

Deciding if a particular case of OOS constitutes serious harm can be difficult.

If a diagnosis of OOS that is work-related is made, or if a VDU user must stop work, or is unable to carry out normal duties because of the severity of work-related pain that he or she experiences, then serious harm may have occurred. As a guide, being unable to carry out normal duties for seven days due to these causes should be taken as evidence of serious harm and should be reported to OSH.

4.5 WORK IN PRIVATE HOMES

There are four likely situations when people may use a VDU at home:

1. A person uses a VDU at home, but not for gain or reward.
The provisions of the Health and Safety in Employment Act, and therefore the recommendations of this code, do not apply. It is common sense, however, that VDU users everywhere attempt to apply the principles and provisions in this code to the workstations in their homes.
2. A self-employed person uses a VDU at home.
Section 17 (duties of self-employed people) applies. Self-employed people are required to take no action, or to fail to act in any way, that harms themselves or any other person.
3. A person is required to work at home by an employer.
The provisions of the HSE Act apply, as if the person were at a place of work under the direct control of the employer.
4. A self-employed contractor is engaged by a principal to do work and uses a VDU to do it at home.
The principal is required (section 18 of the HSE Act) to ensure that no employee of a contractor or sub-contractor is harmed while doing any work that the contractor was engaged to do. In practice, this means that principals engaging contractors should satisfy themselves that the contractors are unlikely to be harmed while working for them. Contractors should be asked to state what health and safety measures they will take to protect themselves from harm, as a part of the tender/contract specification.



Arm rest

A height-adjustable cantilever mechanism device that offers support to the underside of each forearm.

Base support points

The parts of the chair that touch the floor and support the weight of the chair.

Digitiser tablet

An input device, with effects similar to a mouse, often used with CAD systems.

Electronic monitoring

The use of hardware and/or software to record the output of an operator.

Environment

The physical surroundings and conditions of lighting, heating, ventilation and noise.

Ergonomics

The study of the relationships between people and their work.

Flicker

Light that alternately brightens and dims. Flicker on a VDU occurs at between about 50 and 80 times a second and is visible only under certain conditions.

Glare

A bright light in the field of view.

Hardware

The mechanical and electronic components of a computer system.

Illuminance

The amount of light falling on a surface.

ISO

The International Standards Organisation — located in Geneva, Switzerland.

Jitter

A small, jerky repeated motion of the screen image.

Lamp

A light-emitting device — a bulb or a fluorescent tube.

Luminaire

A lighting fixture — the lamp and its mounting and light control surfaces.

Luminance

The amount of light emitted by a lamp.

Lux

A unit of illumination.

Micropause

A brief pause to relax the muscles. The greater the relaxation, the more beneficial the micropause. They ought to be taken frequently — 5–10 seconds

every 3 minutes — for the greatest effect. The micropause allows blood to flow again in a muscle that has been tense.

MicroTesla

A unit of magnetic flux density — how strong the magnetic field is.

Negative display

A method of character display on the VDU screen that shows bright characters on a dark background. (The reverse of paper.)

Offending zone

Luminaires located in the “offending zone” will cause vision problems for office workers. The offending zone is on the ceiling above and in front of the worker.

Performance specification

The degree of performance required. “How much, and of what quality?”

Positive display

A method of VDU screen character display that shows dark characters on a bright background (like paper).

Puck

The input device used at a digitiser tablet. It performs functions almost identical to those of a mouse.

Reflectance

The ratio of the amount of light reflected from a surface to that falling on it.

Rhythm

Movements with a regular beat or cycle of strong and weak elements.

Software

The programs and other operating systems used in a computer.

Swim

A slow, possibly wavy, movement or distortion of the VDU screen image.

Tactile click

A method of signalling that the key has made contact. The operator feels a click as the key is depressed.

Trackball

An alternative to a mouse. Instead of moving the mouse bodily, a large ball in the trackball is rotated with the thumb or fingers.

VDU

Visual display unit. The monitor, keyboard and mouse and computer housing.

Workstation

The desk, chair and so on at which the VDU is used.

Wrist-rest

A support for the heel of the hand placed adjacent to the keyboard at about spacebar height.



REFERENCES

1.
 - ISO 9241. *Ergonomic requirements for office work with visual display terminals*. (See appendix B.)
 - ANSI/HFS 100:1988 *American National Standard for Human Factors Engineering of Visual Display Terminal Workstations*. Human Factors Society, P O Box 1369 Santa Monica, California 90406.
 - BS 7179:1990 *Ergonomics of design and use of visual display terminals*. In six parts:
 1. Introduction
 2. Recommendations for the design of office VDT tasks.
 3. Specifications for visual displays.
 4. Specifications for keyboards.
 5. Specifications for VDT workstations.
 6. Code of practice for VDT work environments.

As the different parts of ISO 9241 become available, the BSI is withdrawing its own standards as appropriate.

 - AS 3590:1990 *Screen based workstations*. In three parts:
 1. Visual display units;
 2. Workstations (including chairs); and
 3. Data entry devices.
2. Swedish Board for Technical Accreditation. *User's Handbook for Evaluating Visual Display Units*. Stockholm, MPR 1990 10, 12-31, (Commonly known as the MPRII.)
3. *Ergonomic Evaluation of Adjustable Office Chairs*. Occupational Safety and Health Service, 1993.

These checklists are based on those developed by Worksafe Australia from anthropometric data for Australians. There is no comprehensive similar data for New Zealanders. The checklists represent the "best" information that is available for New Zealand use in these circumstances.
4. NZS 4303: 1990 *Ventilation for acceptable indoor air quality*. (Based on AHSRAE 62:1989.)
5. AS 2107:1987. *Acoustics — Recommended design sound levels and reverberation times for building interiors*.
6. International Labour Office. *Visual display units: radiation protection guidance*. Occupational Safety and Health Series 70. ILO. Geneva, 1994.
7. National Radiation Laboratory. Unpublished data.
8. WHO offset publication No. 99. *Visual Display Terminals and Workers' Health*, 1987, updated 1990.
9. *Occupational Overuse Syndrome: Treatment and Rehabilitation — A Practitioner's Guide*. Occupational Safety and Health Service, 1992.
10. *Occupational Overuse Syndrome — Guidelines for Prevention and Management*. Occupational Safety and Health Service, 1991.

11. *The Pocket Ergonomist — Clerical/keyboard and industrial/retail versions*. Occupational Safety and Health Service, 1992.
12. Contact the Executive Director, New Zealand Association of Optometrists. P O Box 30 545, Lower Hutt.



APPENDIX A: FURTHER READING

OSH PUBLICATIONS

Occupational Overuse Syndrome — Guidelines for Prevention and Management, 1991.

Occupational Overuse Syndrome — Checklists for the Evaluation of Work, 1991.

Occupational Overuse Syndrome — Pamphlet, 1991.

The “Pocket Ergonomist” — Clerical/keyboard and industrial/retail versions, 1991.

Occupational Overuse Syndrome: Treatment and Rehabilitation — A Practitioner’s Guide, 1992.

An Ergonomic Evaluation of Adjustable Office Chairs, 1993.

“The Floppy Ergonomist”. Software for use with IBM or Macintosh computers.

Atmospheric Conditions in the Workplace.

A Guide to the Health and Safety in Employment Act 1992.

STANDARDS

ISO 9241 *Ergonomic requirements for office work with visual display terminals*. See appendix B.

ANSI/HFS 100:1988 *American national standard for human factors engineering of visual display terminal workstations*. Human Factors Society, P O Box 1369 Santa Monica, California 90406, 1988.

BS 7179:1990 *Ergonomics of design and use of visual display terminals*.

In six parts:

1. Introduction;
2. Recommendations for the design of office VDT tasks;
3. Specifications for visual displays;
4. Specifications for keyboards;
5. Specifications for VDT workstations; and
6. Code of practice for VDT work environments.

AS 3590:1990 *Screen based workstations*.

In three parts:

- Visual display units;
- Workstation (including chairs); and
- Data entry devices.

ACTS AND REGULATIONS

Health and Safety in Employment Act 1992

Radiation Protection Act 1965

Radiation Protection Regulations 1982

OTHER PUBLICATIONS

VDUs in the Workplace — Standards for their safe and efficient use. NZ Council of Trade Unions, Wellington, 1993.

Seating for Office Workers. Department of Health, Wellington, 1988.

Clearing the Air — a health and safety guide to clean air in your office. NZ Council of Trade Unions, Wellington, 1993.

STANDARD ERGONOMIC TEXTS ON VDU WORK

Grandjean, E. *Fitting the Task to the Man.* 4th ed. Taylor and Francis, London, 1988.

Damodaran, L, Simpson A, and Wilson, P. *Designing Systems for People.* NCC Publications, Manchester, 1980.

Sundstrom, E. *Work Places — The Psychology of the Physical Environment in Offices and Factories.* Cambridge University Press, 1986.

Pheasant, S. T. *Bodyspace: Anthropometry, Ergonomics and Design.* Taylor and Francis, 1986.

Shneiderman, B. *Designing the User Interface.* Addison-Wesley, Reading, Massachusetts, 1987.

Eason, K. *Information Technology and Organisational Change.* Taylor and Francis, 1988.

Dainoff, M. J, and Dainoff M. H. *A Manager's Guide to Ergonomics in the Electronic Office.* John Wiley and Sons, New York, 1987.

Grandjean, E (Ed). *Ergonomics and Health in Modern Offices.* Proceedings of International Scientific Congress on Ergonomic and Health Aspects in Modern Offices, Turin, 7-9 November, 1983. Taylor and Francis, 1984. Also, subsequent proceedings from this series of conferences held in 1987, 1990 and 1993.

Fe Josefina, F. Dy. *Visual Display Units: Job content and stress in office work.* International Labour Office, Geneva, 1985.

Chartered Institution of Building Services. *Code for Interior Lighting.* London, 1984.

Chartered Institution of Building Services TM6. *Lighting Guide: Areas for visual display terminals LG3,* London, 1989.

MISCELLANEOUS

The Hand Book — Preventing computer injury. Brown, S. Ergonome, 145 West 96th Street, New York NY 10025, 1993.

Self Report of Discomfort and Pain. A standardised questionnaire available from OSH branch offices.

SCIENTIFIC PAPERS

If you would like to obtain references to scientific information supporting the recommendations here, contact the Information Officer, Occupational Safety and Health Service, Department of Labour, P O Box 3705, Wellington.



APPENDIX B: ISO 9241 ERGONOMIC REQUIREMENTS FOR OFFICE WORK WITH VISUAL DISPLAY TERMINALS

The separate parts of the ISO 9241 standard on the ergonomic design of visual display terminals are as follows. The parts listed in **boldface** have been published. The status of each remaining part is shown by the code that is explained at the bottom of the page.

1. **General introduction** IS
2. **Guidance on task requirements** IS
3. **Visual display requirements** IS
4. Keyboard requirements DIS
5. Workstation layout and postural requirements DIS
6. Environmental requirements CD
7. Display requirements with reflections CD
8. Requirements for displayed colours DIS
9. Requirements for non-keyboard input devices CD
10. Dialogue principles DIS
11. Usability statements DIS
12. Presentation of information CD
13. User guidance CD
14. Menu dialogues DIS
15. Command language dialogues CD
16. Direct manipulation dialogues CD
17. Form filling dialogues CD
18. Flat panel displays CD

Status:

IS Published as an International Standard

DIS Draft international standard.

CD Unpublished committee draft.

Work on the unpublished parts of the standard is proceeding. Enquiries about their status should be directed to the nearest office of Standards New Zealand.

A

absenteeism 14
access (to the workstation) 24,39
accident reporting 56
acoustic hoods 34
adjustability (chairs) 27-29
adjustability (desks) 18
air movement 33
alternative input devices 23
arm-rests 31
arranging equipment 38

B

biological systems 44
bonus systems 17
breaks 18
brightness contrasts 19, 34-35
business planning 15

C

cabling 33
carpet 34
chairs 27-29
colour combinations 20
comfortable temperature 33
computer hardware 18-23
contact lens 45
contracting 56
contrast 19, 34-35
copy-holder 30
curtains 35-36
cushioning 28

D

deadline stress 17
decor 38
dermatitis 47
desk 25-27
detachable keyboards 23
dictaphone (with foot controls) 29
digitiser tablet 23
direct glare 35-37
disability 24
dot-matrix printers and noise 34

E

electric and magnetic field strengths 21-22, 47-48
electronic monitoring 17

epilepsy 46
ergonomics 57
eye fatigue 45
eye-screen distance 39

F

fan outlets 15
filing cabinets 39
flicker (of screen) 57
flickering light 46
foot-rest 29-30

G

general duties (HSE Act) 54
glare filters 37

H

hardware 18-23
harm 54-56
hazard management. 54-55
hazard notification and training. 40-41
Health and Safety in Employment (HSE) Act 53-56
health monitoring 48-51
health problems (of VDU work) 44-48
home use of VDUs 56
humidity 33

I

implosion protection 20
information about hazards 55-56
ISO 9241 10, 18, 63

J

job descriptions 16-17
job rotation 16-17
job satisfaction 14

K

keyboard 22
keyboard skills 41

L

L-return desk 40
laptops 23
laser printers 33-34
left-handed users 24
leg space 26
lighting 34-38
local lighting 38
luminaire placement 36-37

M

micropauses 18
miscarriages 48
monitor (VDU) 19-22
monitor arms 21
monitor height and tilt 20
monitoring employee health 48-51
monotonous tasks 16-17
mouse 22-23
MPRII 22
muscle relaxation 18

N

negative display 34
New Zealand Association of Optometrists 51, 60
noise 34
notebook computers 23

O

obligations
 of employers 11
 of employees 11
occupational overuse syndrome (OOS) 44, 49
offending zone 36
office environment 32-38
organising VDU work 16-18
overtime 17
ozone 33

P

performance specification 16-17
photocopiers 33-34
photogenic epilepsy 46
physical adjustability of the VDU monitor. 20-21
planning for VDU work 14-16
pollution 33
portable computers 23
positive display 23, 35
posture 38,41
pregnancy 14, 48
printers 33-34
private homes, VDU use in 56
puck 23

R

radiant sources of heat 333
radiation 47
reflections 35-37
refresh (flicker) rate 46-47
relaxation 41
reporting, lines of 17

S

screen reflections 35-37

screen adjustability 19-21
screen viewing angle 20
self-employed person 56
serious harm 54-56
short people 25-27
significant hazard 49, 54-55
sit-stand seat 32
skin disorders 47
software 24
sound-absorbing partitions 34
specific duties (HSE Act) 54
spectacles 50, 51
standards 18-19
standing to work 32
stress 17, 45
stressors 46
sub-contractors 56
supervision 17
swim (on the VDU monitor) 19-20, 58
symptoms of:
 occupational overuse syndrome 44
 stress 45-46
 visual and ocular discomfort 45

T

tall people 25, 27
telephone headsets 31
temperature 33
thermal comfort 33
tobacco smoke 33
trackballs 23
training for employees 40, 41
tripping hazards 33

V

variety of healthy postures 24
ventilation 33
vision assessment 50-51
visular and ocular discomfort 45, 50-51

W

wall coverings 34, 38
wiring 33
work monitoring 17
work organisation 16-18, 41
workstation arrangement 38-40

