

- SAFETY
- HEALTH
- WELFARE



## Safety Code for Forklift Truck Operators

---

# No.1 Front Loading Forklift Trucks



Published by the  
Occupational Safety and Health Service



## **APPLICATION**

This Code, which should be read in conjunction with the Approved Code of Practice, applies to front loading forklift trucks but does not include order picking, side loading, or straddle trucks, for which separate codes have been published in the same series of "SAFETY CODE FOR FORKLIFT OPERATORS", as follows:

- No. 2 - Order Picking Trucks
- No. 3 - Side Loading Trucks
- No. 4 - Straddle Trucks

Published by the Department of Labour, New Zealand, on behalf of the Forklift Safety Advisory Committee as set up and approved by the Minister of Labour

First Published: 1979

Revised and reprinted: 1985

(PDF file for web site created October 1999)

---

## CONTENTS

---

	Page
1. Need for This Safety Code	5
2. Types of Accidents Involving Forklift Trucks	6
3. Basic Safety Rules	7
4. Regular and Periodical Inspection	8
4.1 Daily Checks	8
4.2 Weekly Checks	9
4.3 Environment Inspection	9
5. Driving Procedures	10
6. Ramps and Loading Docks	18
7. General	20
8. Basic Stacking Rules	22
9. Basic Destacking Rules	25
10. Reach Trucks - Additional Rules for	30
11. Pedestrian-Operated Vehicles - Additional Rules for	32
12. Appendix A: Daily Check Report (Battery-Powered Forklift Trucks)	34
13. Appendix B: Daily Check Report (Engine-Powered Forklift Trucks)	35
14. Appendix C: Daily Check Report (LPG-Powered Forklift Trucks)	36
15. Appendix D: Weekly Inspection and Maintenance Report	38

---

---

## **ARE YOU THE RIGHT PERSON FOR THE JOB?**

You are when you have been properly trained and have read and understood this booklet, especially the simple rules for safety. Reading this booklet periodically will ensure that you are at all times aware of the rules for safety and thus remain the right person for the job.

## **REMEMBER**

**ONLY TRAINED AND AUTHORISED OPERATORS ARE PERMITTED TO USE FORKLIFT TRUCKS.**

---

---

# **1. THE NEED FOR THIS SAFETY CODE AND WHY YOU SHOULD READ, UNDERSTAND AND FOLLOW IT**

---

---

It is a matter of grave concern that a large number of serious and fatal accidents involving forklift trucks occur every year, especially when it is known that most of these accidents can be prevented.

Main causes of accidents involving a machine of this type may be cited as:

- 1.1 Lack of knowledge or skill.
- 1.2 Operator not attentive to the job at hand.
- 1.3 Operator taking chances, with full knowledge of possible consequences.
- 1.4 Poor maintenance.
- 1.5 Mechanical malfunction.
- 1.6 Constructional defect in some part of the machine.

The operator has no control over item 1.6 listed above. Mechanical malfunctions, item 1.5 above, cause only a minor fraction of total accidents, and in many cases accidents may be prevented by regular maintenance and checks.

---

It is recognised that the operator may not be qualified, experienced, or authorised to carry out maintenance or repairs. However, it is the operator's duty to check that the machine is in a satisfactory working condition before operating it and any faults or shortcomings should be brought to the notice of the person in charge.

With regard to the first three causes listed above, it is obvious that these can be avoided to a great extent, when there is deliberate effort on the part of the operator.

---

---

## **2. LIKELY TYPES OF ACCIDENTS INVOLVING FORKLIFT TRUCKS**

---

---

- 2.1 Person being struck by a moving forklift truck.
- 2.2 Operator hit by a falling object.
- 2.3 Other employee/person hit by a falling object.
- 2.4 Boarding or leaving the forklift truck.
- 2.5 Forklift truck tipping over.
- 2.6 Collision with other vehicles or stationary objects.
- 2.7 Part of the operator's body (protruding outside the cab) hitting an object.
- 2.8 Accidents to passenger riding on the forklift or on the forks.

---

### **3. BASIC SAFETY RULES**

---

---

- 3.1 Forklift trucks are to be driven only by trained and competent operators acting under proper authority.
- 3.2 Operators should be physically fit, to ensure satisfactory speed of reaction and a high standard of vision and judgement of distance.
- 3.3 Operators must be alert at all times to avoid accidents.
- 3.4 Operators must check that their forklift truck is in good working condition and has been properly maintained.
- 3.5 If at any time the forklift truck develops a fault, or if there is reason to think it unsafe, stop and report immediately to the appropriate authority. Do not use again until repairs have been made.
- 3.6 Unless specifically authorised, and able, do not attempt repairs or adjustment to forklift trucks.
- 3.7 Load pallets evenly; avoid building up unstable loads which could collapse when moved.
- 3.8 Look all around you before moving the forklift truck.

- 
- 3.9 Loads must be strictly within the weight and load centre capacity limits of the truck as shown on the load plate.
  - 3.10 Never operate the forklift truck on gradients with the load elevated more than necessary.
  - 3.11 When turning from one aisle into another, exercise caution, driving with load as low as is convenient. Cross intersections with care.

---

---

## **4. REGULAR AND PERIODICAL INSPECTION**

---

---

### **4.1 DAILY CHECKS**

Appendices A, B and C on pages 34, 35 and 36 show the suggested forms and details of checks that should be carried out. Any points applicable to a particular make of machine and not covered in these check lists can be added.

Appendix A relates to battery-powered forklift trucks, Appendix B relates to engine-powered forklift trucks, and Appendix C relates to LPG-powered forklift trucks.

---

## **4.2 WEEKLY CHECKS**

---

---

It is recommended that these be carried out by a suitably trained person who is also authorised for the job. The operator should, however, confirm that regular weekly checks have in fact been carried out.

Although some items of inspection are listed in Appendix D, these are only of a general nature and by no means comprehensive. Manufacturers' recommendations are to be followed where applicable. This also gives the operator an idea as to which items of machinery should be inspected at least once a week.

---

---

## **4.3 ENVIRONMENT INSPECTION**

---

---

- 4.3.1 Note low clearances such as pipes, sprinklers, doorways, overhead power lines, etc.
- 4.3.2 Be sure that the floor and bridging plates can support the combined weight of your forklift truck and load.
- 4.3.3 Check the floors for damage, wetness, greasy or oily surfaces or obstructions in aisles. These may affect the stability of the forklift truck.

---

## 5. DRIVING PROCEDURES

---

- 5.1 Always carry loads as near to the ground as practicable. In the event of brake failure, lower the load to the ground.
- 

- 5.2 Look in the direction of travel and keep a clear view of the way ahead. (If vision is obscured, seek assistance or travel in reverse.)

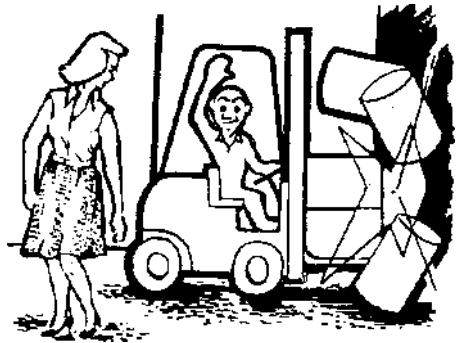

- 5.3 Remember the effect of tailswing. To make a turn, drop the speed and take care that the tip of the fork (or load) or rear side of the machine does not touch or bump against any object or person nearby.

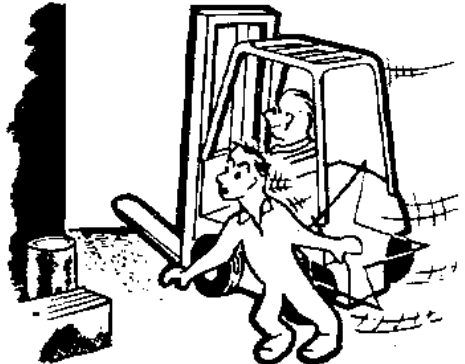

---

5.4 If a bulky load obscures forward vision, drive in reverse. However, the load must lead (be on the uphill side), when travelling up gradients.

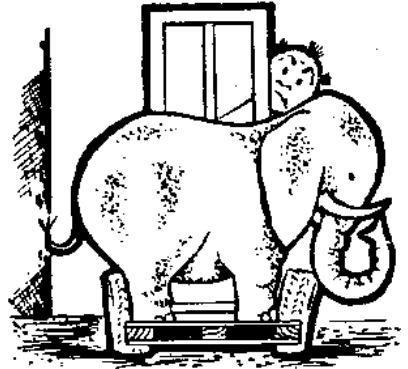

---

5.5 Only carry loads that are supported by the carriage or the back-rest extension.



---

5.6 Drive at a speed consistent with existing conditions. Slow down for wet or slippery surfaces.

---

- 
- 5.7 Keep a safe braking distance from the truck in front and never overtake when approaching cross roads or in blind areas.

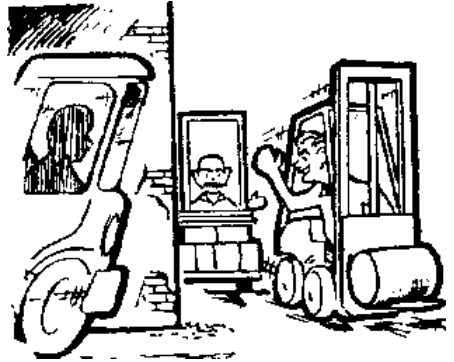

- 
- 5.8 When approaching crossings in aisles or gangways, slow down, sound horn, and if vision is obstructed keep well to the correct side of the aisle.

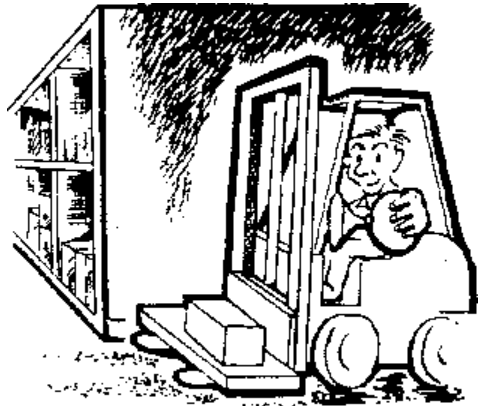

- 
- 5.9 Because of the varying needs of industry, it is not practical to recommend driving on the left or right, but it is suggested that the broad principle of the Road Code be observed.

- 
- 5.10 Passengers must not be permitted to ride on the forks or load or any other part of a forklift truck.



- 
- 5.11 The use of a forklift as a hoist for personnel must not be permitted unless a work platform complying with NZ Standard 5426 has been fitted.

- 
- 5.12 Avoid making fast starts, jerky stops, and quick turns, particularly if materials are being stacked at height.

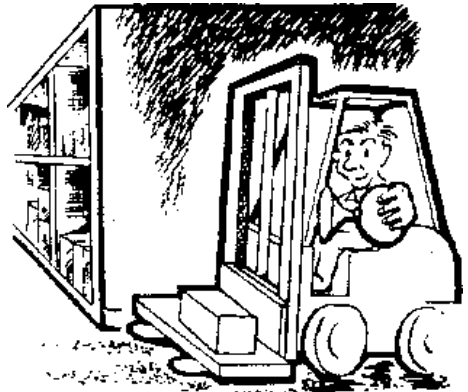

- 
- 5.13 Do not run over loose objects. Stop the forklift truck, remove objects (dunnage, etc) to the side of the aisle and report to supervisor.
- 

- 5.14 Never attempt to handle loads that exceed the forklift truck's rated capacity. This involves not only weight, but the load centre. Remember the allowable load to be carried is reduced if a high lift is involved (refer to the forklift truck load chart rating).

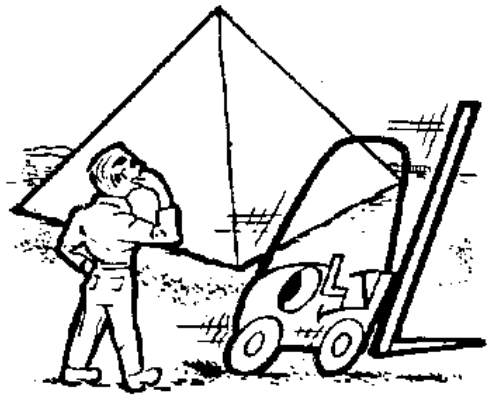

- 
- 5.15 Never cross railway lines unless the lines have been recessed into the surface.

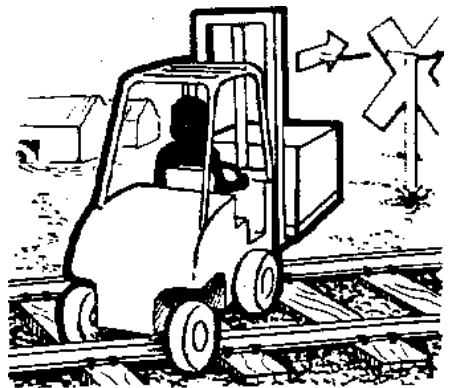

---

5.16 Never park a forklift so that any part is closer than 2.5m from any railway line.

---

5.17 Never use a forklift truck to tow or push railway cars or wagons.

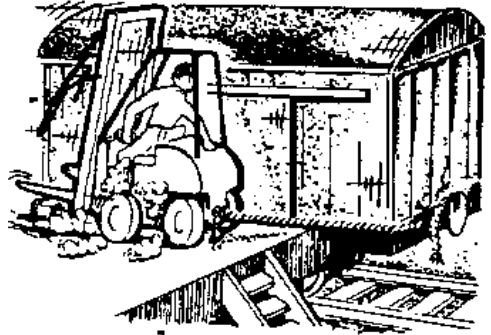

---

5.18 Never push on the point of one or both forks.

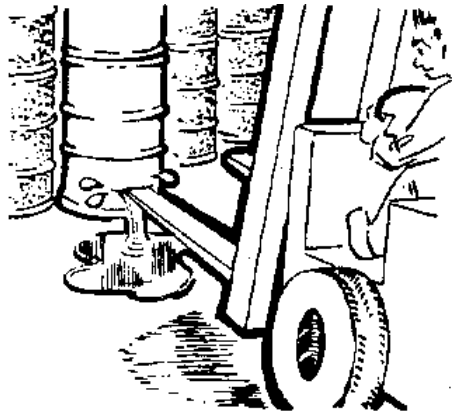

- 
- 5.19 Never attach a tow rope to the mast to pull or drag loads.

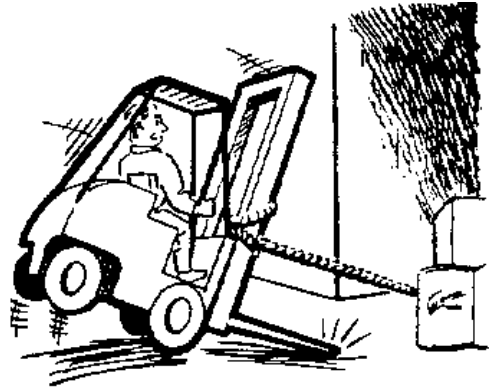

- 
- 5.20 Forks should always be driven well under the load, preferably for their full length. When travelling, the back of the load should be firmly located against the fork carriage or back-rest and the mast tilted back sufficiently to safeguard load.

- 
- 5.21 When a forklift truck is travelling without a load, its forks should be around 150mm (6 inches) above the ground.

- 
- 5.22 Do not allow anyone to stand or walk under the elevated forks, whether or not a load is being carried.
-

- 
- 5.23 Before moving off look around, use mirror if fitted, and when clear move off without inconveniencing other users of the aisle.

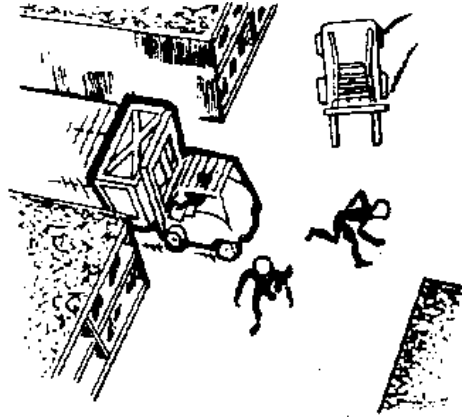

- 
- 5.24 When traffic signs and signals are in use, learn and act upon them.

- 
- 5.25 Where no traffic signs or signals exist, try to give a clear indication of your intention to other aisle users.

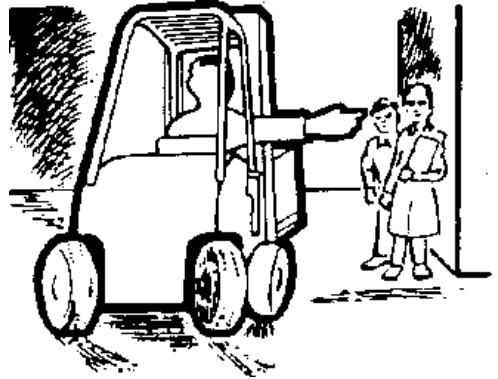

- 
- 5.26 Drive carefully and slowly, especially when pedestrians are about.

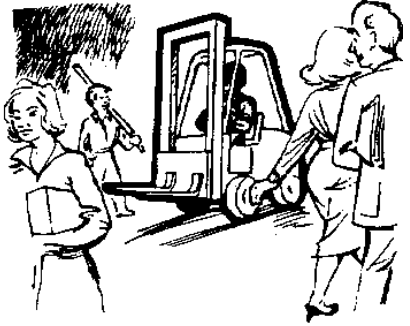

---

## 6. RAMPS AND LOADING DOCKS

---

- 6.1 Never drive over a bridge plate unless you are satisfied that it will support the weight of your forklift truck and load and it is securely fixed. Then drive over very slowly.

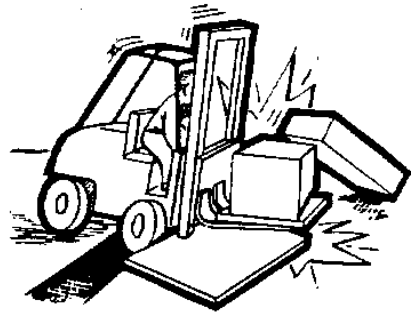

---

6.2 Before entering a truck, trailer, or railwagon, its brakes should be set and its wheels chocked. Semi-trailers must have fixed jacks to prevent upending.

---

6.3 A forklift truck must never be left on an incline.

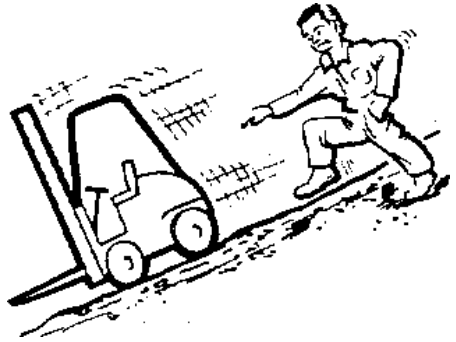

6.4 (i) When travelling on an incline and carrying a load, the load must always be on the uphill side of the forklift truck.

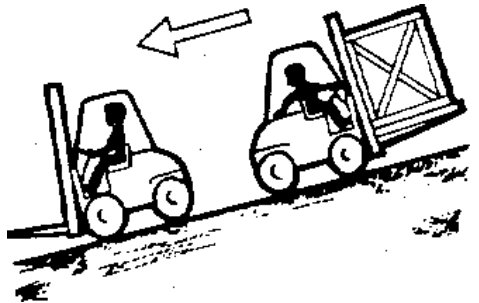

(ii) When travelling on an incline without a load, the forks must always be on the downhill side of the forklift truck.

- 
- 6.5 On all gradients, the mast must be tilted back sufficient to safeguard the load and the forks raised high enough to clear the ground.
- 

- 6.6 Never stack on gradients.

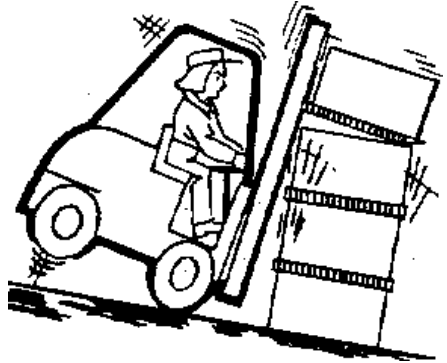

---

## 7. GENERAL

---

- 7.1 Never remove a back-rest extension or overhead guard unless specifically authorised.
- 

- 7.2 Never place arms, hands, legs, or head between the uprights of the mast or outside the limits or the forklift truck's body or cab (except when hand-signalling a turn or other manoeuvres).

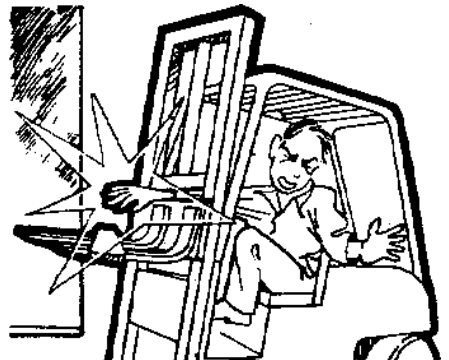

---

7.3 Never allow an engine-powered truck to remain stationary in confined spaces for long periods with its engine running. The build-up of fumes and gases can be dangerous.

---

7.4 When leaving the forklift truck, ensure that the controls are at “neutral”, power is shut off, brakes applied, forks fully lowered, and the ignition key or starter switch key removed. (This helps prevent unauthorised people from using the machine.)

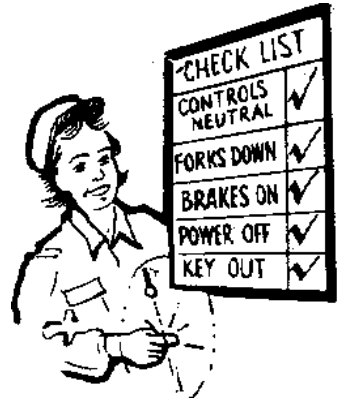

---

7.5 Under no circumstances must additional counterweights be added to forklift trucks to increase their load-carrying capacity without prior reference to the manufacturer. No person should stand or sit on the counterweight.

---

7.6 Do not fit extensions to forklift trucks unless their use is authorised. Only fork extensions of a design approved by the manufacturer may be used.

---

---

7.7 All repairs, rebuilds or adjustments shall be made in accordance with the manufacturer's design criteria.

---

7.8 When flashing lights or reversing beepers are fitted, ensure that these are operating correctly. Horns are used only when necessary.



---

7.9 When a forklift truck or any part of its load has to be closer than 4 metres to any live electrical wire or installation, the Electrical Supply Authority should be contacted.

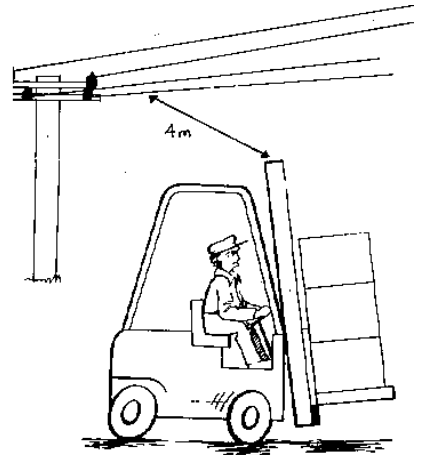

---

7.10 In the event of a forklift truck contacting a power line:

(i) Stay where you are and keep others away.

(ii) If possible, move the truck off the power line.

(iii) If you must leave the truck, jump well clear. **DO NOT** touch the truck—you may be killed.

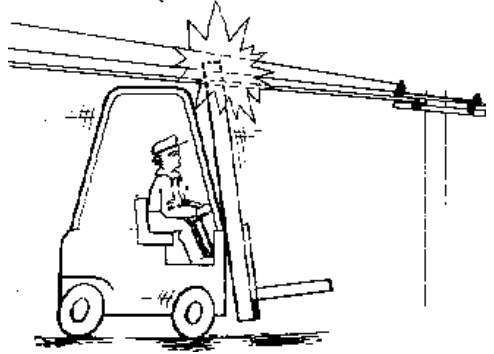

---

7.11 If the power line is broken:

(i) **DO NOT** get off the truck.

(ii) Wait until the power is shut off before leaving the truck or allowing anyone to come near.

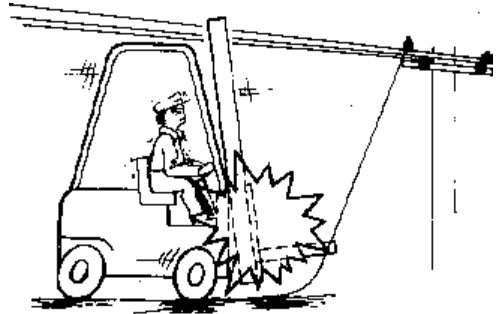

---

## 8. BASIC STACKING RULES

---

- 8.1 Approach the stack with the load low and tilted backward.

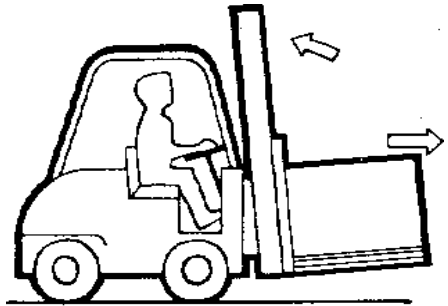

- 
- 8.2 Slow down and stop at the face of the stack, reducing backward tilt to an amount just sufficient to stabilise the load. Handbrake on, gear lever into neutral.

- 
- 8.3 Bring mast forward retaining only sufficient back tilt to secure load. Raise the load to the desired stacking height.

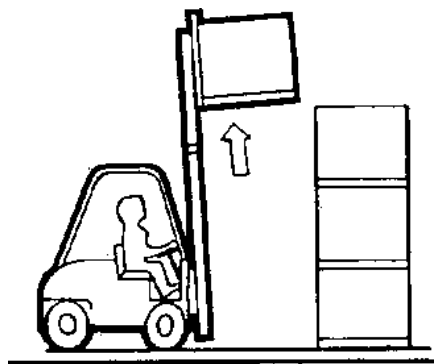

- 
- 8.4 When the load is clear of the top of the stack, move slowly forward.

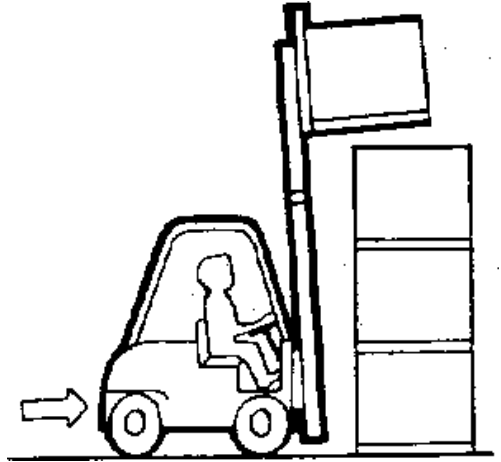

- 
- 8.5 When the load is over the stack, bring the mast to the vertical position and lower the load on to the stack.

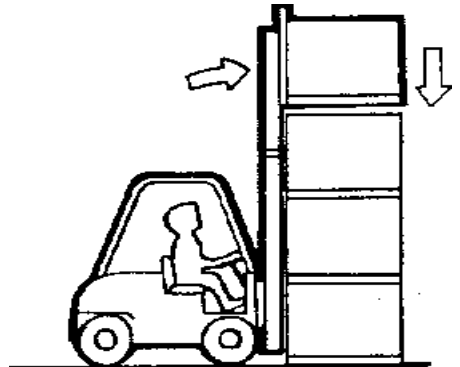

- 
- 8.6 When the load is securely stacked, lower forks until free of pallet or dunnage strips, check behind and withdraw by reversing the forklift truck. At this position slight forward tilt may be of assistance, other wise it should seldom be necessary to use forward tilt.

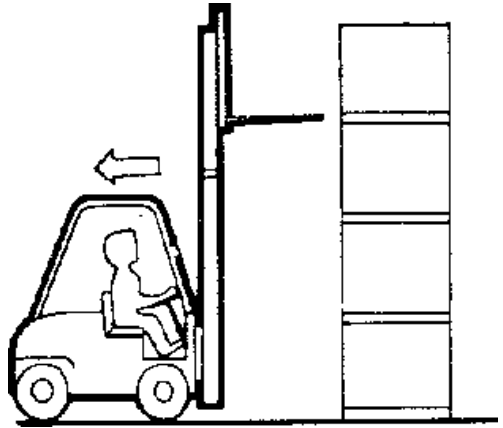

- 
- 8.7 When clear of the stack, lower the forks to just above the ground level, then tilt the mast backward to the normal travelling position.

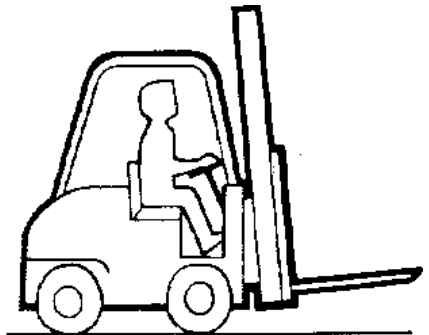

- 
- 8.8 The stack should not be straightened by pushing against the stack with the forks or the end of the forklift truck.

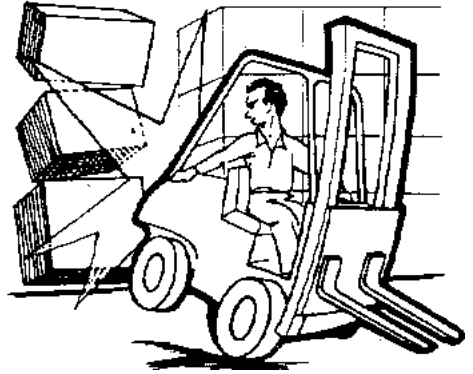

---

## 9. BASIC DESTACKING RULES

---

- 9.1 Halt at the face of the stack, bringing mast to the vertical position.

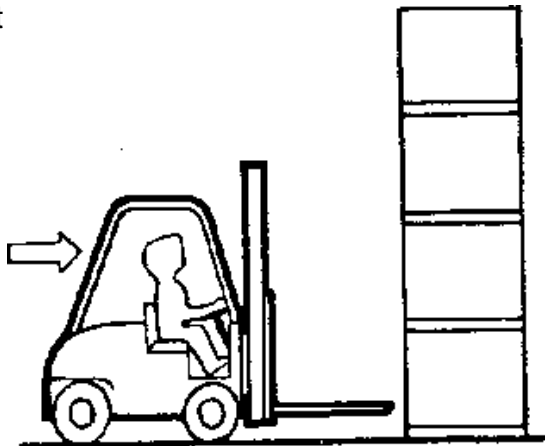

- 
- 9.2 Raise forks to a position permitting clear entry into pallet or dunnage strips.

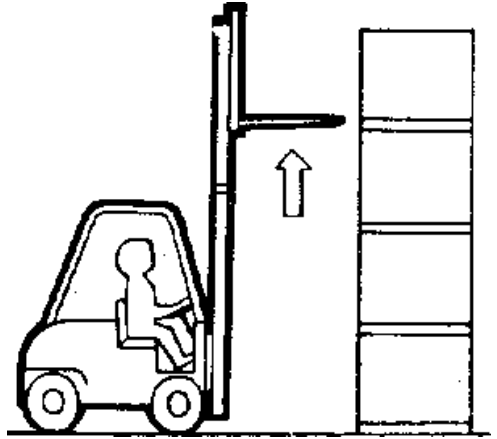

- 
- 9.3 Slowly drive forward until the back-rest is against the load. Slight forward tilt may be of assistance at this stage. Ensure the lower parts of the mast do not hit the stack when moving forward.

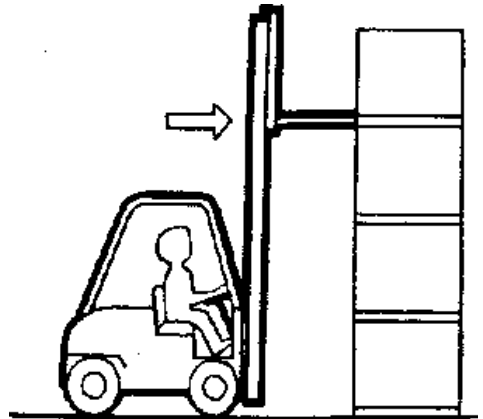

- 
- 9.4 Lift load until clear of stack and apply backward tilt just sufficient to stabilise the load.

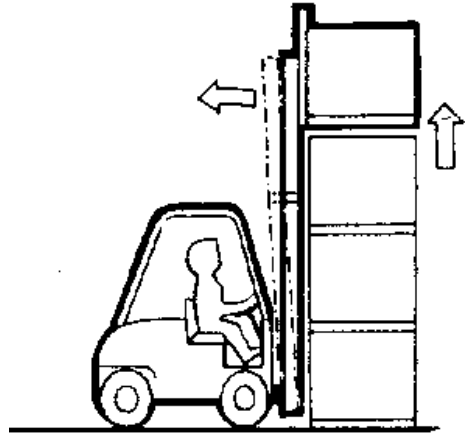

- 
- 9.5 When the load is clear of the top of the stack, check behind and then move slowly backward to clear face of stack.

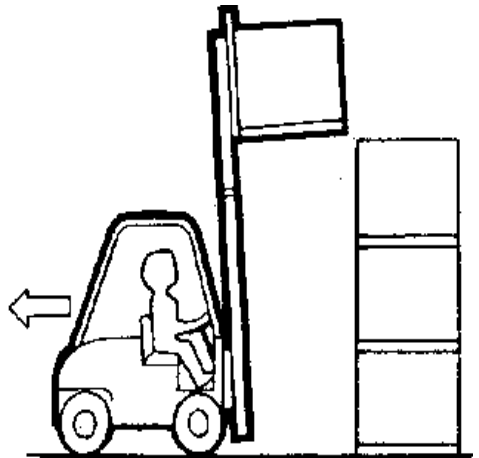

- 
- 9.6 Lower the load to the correct carrying height, before applying further backward tilt, to bring into normal travelling position.

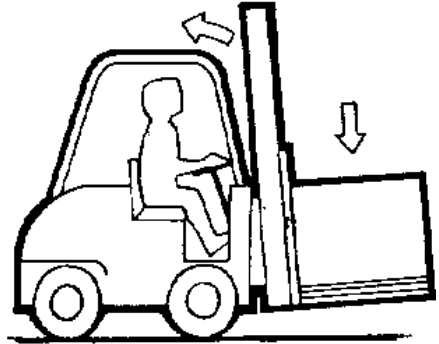

- 
- 9.7 Extreme care must be taken to avoid jerking when tilting a load forward or backward, especially when the load is at height.
- 

## 10. ADDITIONAL RULES FOR REACH TRUCKS

---

---

- 10.1 Never drive a reach truck, whether laden or unladen, with the reach mechanism extended.

---

10.2 Before operating the reach mechanism of reach trucks, make sure the brakes are applied.

---

10.3 Never allow anyone to step over the reach legs, or insert a limb between mast and power unit, while the reach truck is being operated.

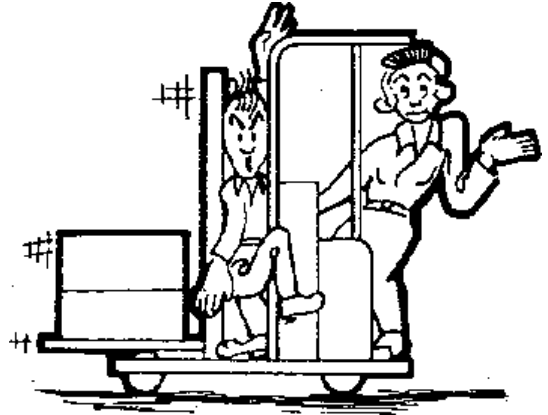

---

10.4 Do not use the reach movement by itself as a means of pushing or dragging loads into position.

---

10.5 Be sure that the load is raised just above the reach legs before retracting.

---

---

## **11. ADDITIONAL RULES FOR PEDESTRIAN-OPERATED VEHICLES**

---

---

- 11.1 Because pedestrian-controlled powered forklift trucks are often used by untrained personnel, it must be emphasised that the general rules in this publication apply equally to pedestrian-controlled forklift trucks.

### **EACH OPERATOR IS RESPONSIBLE FOR REPORTING ANY FAULTS WITHOUT DELAY**

---

- 11.2 The following are additional rules:
- 11.2.1 If for any reason an emergency arises, completely release the control handle thereby allowing the “dead man brake” to function.

---

11.2.2 When reversing in very confined areas, keep your feet clear of the forklift truck's chassis.

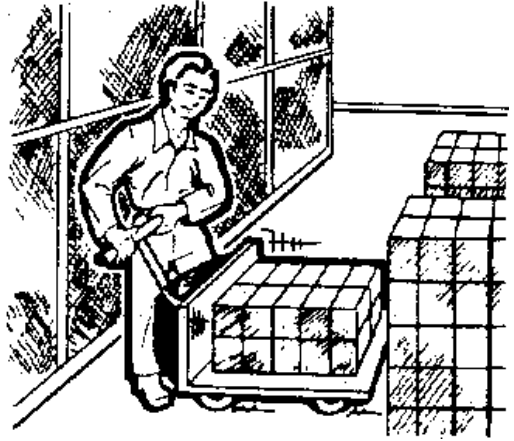

---

11.2.3 When reversing from a stack, always ensure that there is sufficient space between the control handle and the stack or rack behind you.

**APPENDIX A:  
OPERATOR'S DAILY CHECK REPORT  
BATTERY-POWERED FORKLIFT TRUCKS**

Forklift Truck No. .... Make: .....  
 Date: ..... Shift: .....  
 Hour meter reading: Start: ..... End: .....  
 Hours for shift: .....

CHECK EACH ITEM if OK, write OK taken	SHIFT			Explain below if not OK or any other action
	Start	During	End	
1. Battery plug connection				
2. Battery charge and electrolyte				
3. Battery load test				
4. Brakes				
5. Lights - head, tail, warning, and indicating				
6. Horn				
7. Hour meter				
8. Steering				
9. Tyre				
10. Hydraulic controls				
11. Other items				

Remarks or additional explanations or suggestions:

Operator's signature:

**APPENDIX B:  
OPERATOR'S DAILY CHECK REPORT  
ENGINE-POWERED FORKLIFT TRUCKS**

Forklift Truck No. .... Make: .....  
 Date: ..... Shift: .....  
 Hour meter reading: Start: ..... End: .....  
 Hours for shift: .....

CHECK EACH ITEM if OK, write OK	SHIFT			Explain below if not OK or any other action taken
	Start	During	End	
1. Fuel level				
2. Oil level and pressure				
3. Water level and fan belt				
4. Brakes				
5. Steering				
6. Lights - head, tail warning and indicator				
7. Horn				
8. Hour meter and gauges				
9. Tyres				
10. Hydraulic controls				
11. Other items				

Remarks or additional explanations or suggestions:

Operator's signature:

## APPENDIX C: OPERATOR'S DAILY CHECK REPORT LPG-POWERED FORKLIFT TRUCKS

Forklift Truck No. .... Make: .....  
 Date: ..... Shift: .....  
 Hour meter reading: Start: ..... End: .....  
 Hours for shift: .....

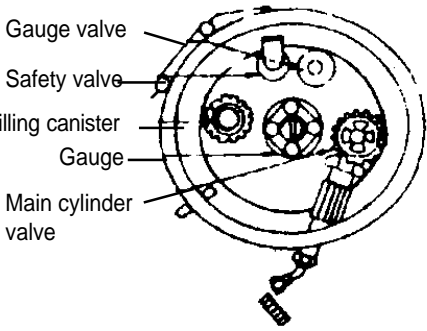
CHECK EACH ITEM if OK, write OK	SHIFT			Explain below if not OK or any other action taken
	Start	During	End	
<p>1. Check that the LPG gas cylinder is properly mounted in the correct radial position in its mounting brackets.</p> <p>2. Check that the safety relief valve is positioned as per the diagram below:</p> <div style="text-align: center;">  </div> <p>3. Check the level of fuel in the cylinder. (Gauge at end of cylinder).</p>				

<ol style="list-style-type: none"> <li>4. Check that the regulator, hose and fittings are free of wear, leaks or defects.</li> <li>5. If the forklift truck is dual-fuelled, check that there is adequate petrol in the event of a fuel change-over becoming necessary.</li> <li>6. Check that items 2-11 in Appendix B are satisfactory.</li> </ol>				
--	--	--	--	--

**WARNING: LPG MAY COLLECT IN UNSEEN POCKETS OF THE CHASSIS TO FORM A POTENTIAL EXPLOSIVE HAZARD. OPERATORS SHOULD NOT SMOKE WHILE CHECKING, MAINTAINING OR FUELLING THE VEHICLE.**

**CNG CYLINDERS:** These cylinders are permanently situated on the forklift truck and item 1 (above) may not be applicable.

**APPENDIX D:  
WEEKLY INSPECTION AND  
MAINTENANCE REPORT**

Forklift Truck No. .... Make: .....  
Date: ..... Hour Meter: .....

CHECK EACH ITEM if OK, write OK	REMARKS	ACTION TAKEN (if any)
1. Hydraulic rams 2. General lubrication 3. Hydraulic system (hoses etc) 4. Limit switches 5. Brake fluid 6. Lifting chains, pulleys, wire ropes 7. Forks and retain- ing pins 8. Overhead guard and load back- rest 9 Other items		

Additional explanation or suggestions/recommendations:

Engineer's signature: